

# News from Rohde & Schwarz

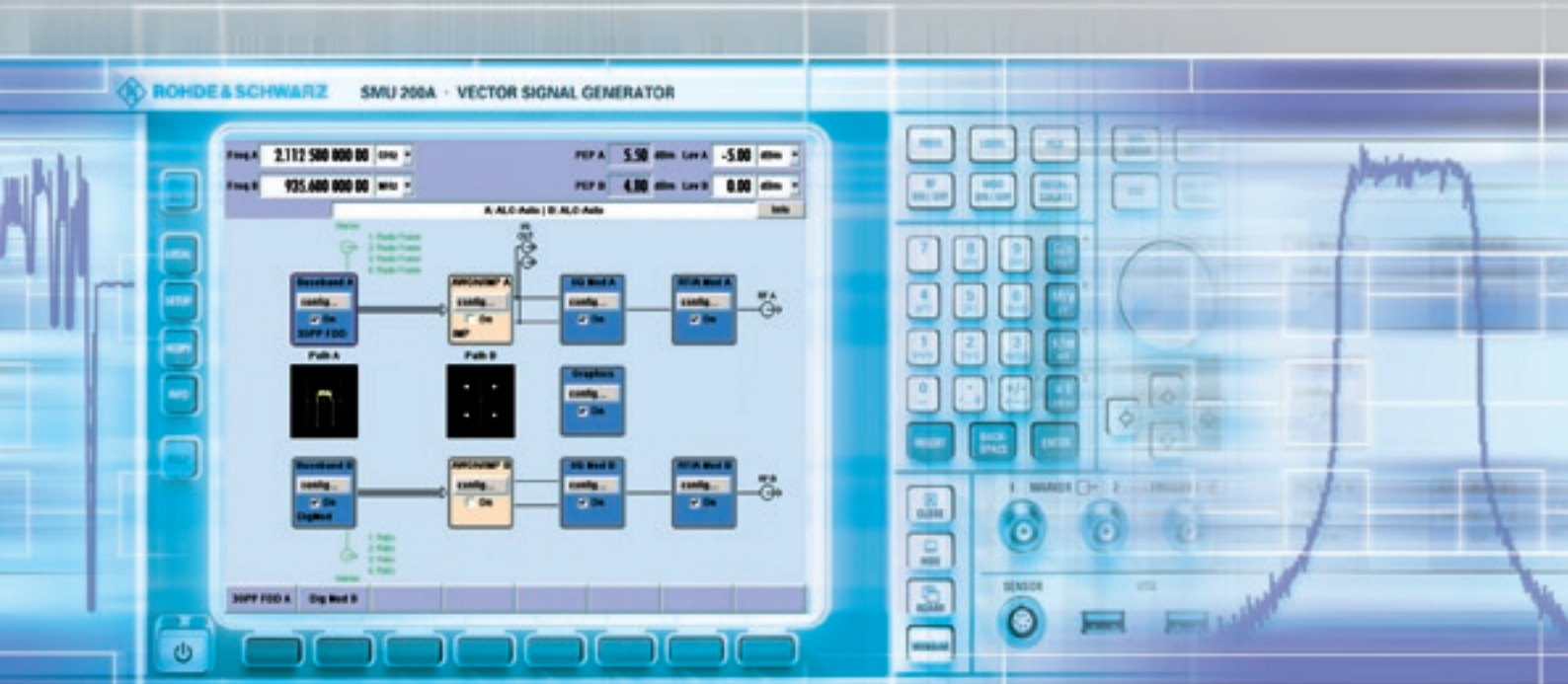

Two new vector signal generators:  
affordable or high-end

UMTS radio network analyzer: maximum  
information from the air interface

Broadband digital monitoring direction  
finder for complex radio scenarios

2003/IV

180



**ROHDE & SCHWARZ**

An outstanding achievement: The Vector Signal Generator R&S®SMU200A as the follow-up instrument to the successful Signal Generator R&S®SMIQ excels at flexibility and performance. It is the first high-end generator to contain two complete signal generators with digital modulation capability in a single instrument. A novel operating concept facilitates the overview of the numerous functions (page 21).



44104



The universal UMTS Radio Network Analyzer R&S®TSMU is setting new standards in coverage measurement. The intelligent combination of the instrument with test mobile phones enables maximum information to be determined from the air interface (page 4).

MOBILE RADIO

Coverage measurement systems

- ◀ Radio Network Analyzer R&S®TSMU  
Performance giant in compact format sets new standards ..... 4

Test systems

- Minimizing measurement uncertainties
- Why Rohde & Schwarz test systems are so exacting ..... 8

Radiocommunication testers

- Universal Radio Communication Tester R&S®CMU200
- Handover scenarios in GSM systems ..... 12

GENERAL PURPOSE

Test systems

- Open Test Platform R&S®CompactTSVP
- Modular test equipment based on CompactPCI/PXI ..... 14

Signal generators

- Vector Signal Generator R&S®SMU200A – The art of signal generation ..... 21
- Vector Signal Generator R&S®SM300
- ◀ Wide variety of test signals at an excellent price ..... 28

Spectrum analyzers

- Signal Analyzer R&S®FSQ / Spectrum Analyzer R&S®FSP
- WLAN measurements with analyzers from Rohde & Schwarz ..... 32
- Spectrum Analyzer R3681 from Advantest
- Broadband modulation analysis for wireless LAN ..... 36

Network analyzers

- RF Component Analyzer R3860A from Advantest
- Network and component analysis made easy ..... 39



Whether in the development lab, in service or remotely controlled in production, the new Vector Signal Generator R&S®SM300 is an ideal choice if you need a favourably priced signal source. Despite its low price, this signal generator meets virtually every requirement (page 28).

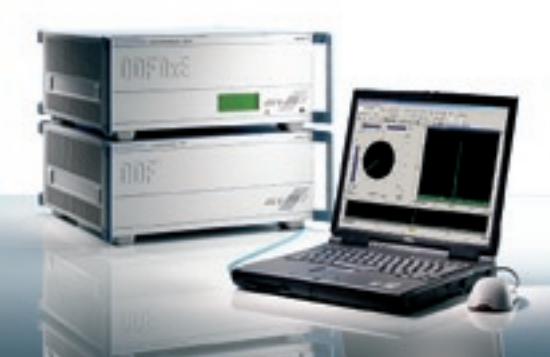

Depending on the selected resolution bandwidth, the new direction finders of the R&S DDF® 0xE family are able to take bearings of up to 10 000 frequency channels simultaneously in the realtime bandwidth of 1 MHz in the HF range and of 2 MHz in the VHF/UHF range (page 54).



Rohde & Schwarz FTK GmbH delivered a shelter station for a wind profiler that went into continuous operation at the German Meteorological Service in September 2003. The pulse transmitter is a modified DVB-T transmitter from Rohde & Schwarz (page 58).

## Power meters

Power Meter R&S® NRP  
 Evolution in motion – new functions and sensors ..... 42

## Power supplies

Dual-Channel Analyzer / Power Supply R&S® NGMO 2  
 R&S® Current Sniffer: tracking down energy guzzlers..... 45

## EMC / FIELD STRENGTH

### Test methods

Portable System for EMF Measurements R&S® TS-EMF  
 How ambient conditions influence electromagnetic field measurements ..... 48

## BROADCASTING

### Sound transmitters

DAB VHF Transmitter Family R&S® NA 7000  
 Liquid-cooled high-power DAB transmitters..... 50

### Reference

Mobile FM transmitter system for Bayerischer Rundfunk ..... 52  
 Digital TV in Italy launched with Rohde & Schwarz – The donna wears leopard ..... 53

## RADIOMONITORING

### Direction finders

Digital HF/VHF/UHF Monitoring Direction Finder R&S DDF® 0xE  
 Complex radio scenarios monitored at a glance ..... 54

## FOCUS

### Wind profiler

◀ Wind profiler for the German Meteorological Service..... 58

## MISCELLANEOUS

Newsgrams..... 62

Published by Rohde & Schwarz GmbH & Co. KG · Mühldorfstrasse 15 · 81671 München  
 Support Center: Tel. (+49) 01805 124242 · E-mail: customersupport@rohde-schwarz.com  
 Fax (+4989) 4129-13777 · Editor and layout: Ludwig Drexler, Redaktion – Technik (German)  
 English translation: Dept. 9UK7 · Photos: Rohde & Schwarz · Circulation (German, English, French, Russian and Chinese) 90 000 approx. 4 times a year · ISSN 0028-9108 · Supply free of charge through your nearest Rohde & Schwarz representative · Printed in Germany by peschke druck, München · Reproduction of extracts permitted if source is stated and copy sent to Rohde & Schwarz München.



44064/6

FIG 1 The Radio Network Analyzer R&S® TSMU, used inhouse together with the UMTS test phone Qualcomm 6200 and Bluetooth™ GPS receiver on a tablet PC.

Following the introduction of the UMTS PN Scanner R&S® TS5K51C [1] a year ago, Rohde & Schwarz is now setting new standards in performance, precision and speed for mobile phone measurements in 3GPP networks with the next phase in development – the compact and universally implementable UMTS Radio Network Analyzer R&S® TSMU.

## Radio Network Analyzer R&S® TSMU

# Performance giant in compact format sets new standards

### Greater performance in even less space

The R&S® TSMU and the accompanying R&S® ROMES-US2 UMTS software stand out particularly because of the following features:

- ◆ Multitechnology capability (2G/3G) in a single instrument
- ◆ Parallel PN scanning of up to 12 RF channels in one mobile radio band
- ◆ Time-variant spectrum analysis from 15 MHz to 3 GHz parallel to PN code measurements
- ◆ All measurements done at top speed, dynamic range and precision (see page 7 for specifications)
- ◆ Efficient control with Coverage Measurement Software R&S® ROMES [2]
- ◆ Also for inhouse use due to portability and low energy consumption
- ◆ Automatic application-specific firmware adaptation (FPGA and software)

The R&S®TSMU consists of an RF receiver for 100 kHz to 3 GHz, a processor board with a field programmable gate array (FPGA) core, a power PC and a power supply unit with an input voltage range from 9 V to 18 V.

On the processor board, the IF data of the RF receiver is collected, synchronized, filtered and forwarded to the controller via the FireWire interface (IEEE 1394). Within the controller, the data is further processed by Measurement Software R&S®ROMES and then recorded and displayed with the measurement results of the GPS receiver and the UMTS mobile telephone.

The compact and robust housing indicates the various operating states by means of LEDs. Connections for antenna, GPS, distance trigger, FireWire and power supply are located at the rear (FIGs 1 and 2).

### Better properties through state-of-the-art technology

The R&S®TSMU is one of the first instruments in the world that uses the new VIRTEX-II PRO™ DSP technology for optimum signal processing and instrument control.

The RF receiver is directly controlled by hardware components in the FPGA unit of the VIRTEX-II PRO™, allowing the system to respond extremely quickly to changes in reception in mobile use. Given the minimum delays between the on-chip power PC and the FPGA as well as the broadband data connection to the controller, it was possible – together with distributed DSP algorithms – to achieve higher measurement rates than in its predecessor. The 64 Mbyte signal memory ensures that weak interfering UMTS signals can be found, and it is required in order to prevent ghost code results. Four thermometers distrib-

uted within the instrument allow exact corrections of measurements in different temperature ranges as soon as the instrument is switched on; the basic frequency of the R&S®TSMU can additionally be tracked together with the measured UMTS time frames or, even more precisely, with a GPS seconds pulse sequence. A 256 Mbyte to 2 Gbyte compact flash memory can be used to store comprehensive calibration and measurement data.

To achieve the best possible RF characteristics for the R&S®TSMU at minimum size and low power consumption, components from the newest Rohde & Schwarz spectrum analyzers were used. For these special tasks in the R&S®TSMU, their noise figure for measurements of weak antenna signals was reduced and the IF bandwidth for the measurement of 3GPP signals was enlarged.

The R&S®TSMU is the new hardware platform for almost any application involving mobile radio network optimization. Its architecture is already designed for expansions to HSDPA, GSM / GPRS, cdma2000, TD-SCDMA and CW. The required firmware is automatically loaded by Measurement Software R&S®ROMES via the FireWire interface.

### In-depth radio network analysis with test mobile phones

Specifically the combination of the R&S®TSMU with UMTS test mobile phones (FIG 1) provides an exceptional tool for in-depth analysis of air interface problems. Test mobile phones provide a limited picture of the RF situation in the network. The R&S®TSMU enriches the information from the mobile phone with a complete RF analysis that can be used to find the cause of the prob-



**FIG 2** Rear view of the R&S®TSMU with synchronization and pulse input (top right), antenna socket and two FireWire connectors for cascading up to 62 R&S®TSMU analyzers on one controller. The RS-232-C interface supplies service information.

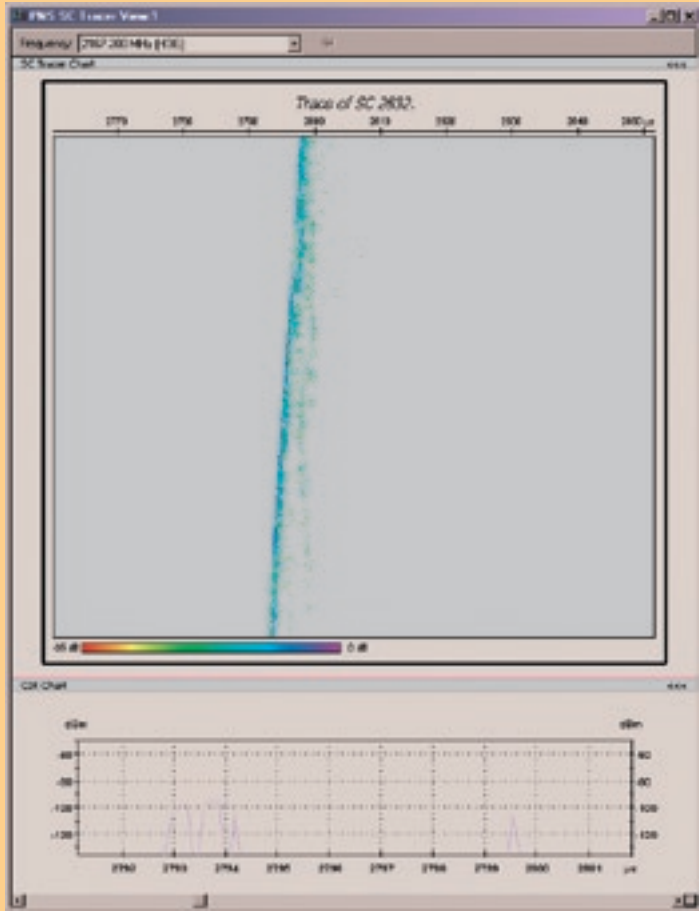

**FIG 3**  
Channel impulse response on scrambling code 2832 with 2D and waterfall display during drive test with the R&S® TSMU. Strong reflections and time drift of the base station are clearly indicated.

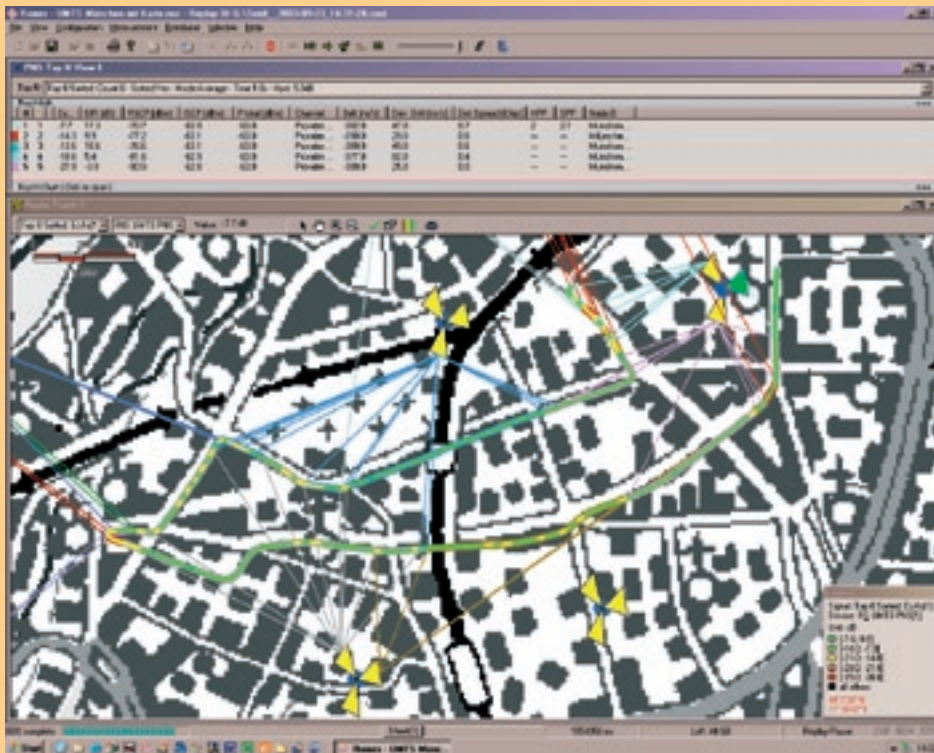

**FIG 4** Drive test with the R&S® TSMU in best server/TOP-N display. The colour of the route marks the  $E_c/I_0$  value of the best server. The contour of the route has the scrambling code colour. Each line from the test vehicle to a base station shows a change in the best server in the colour of the new scrambling code.

► lems reported by the mobile phone. This includes interference from outside the network, defects in the base station and unavoidable differences between planning and implementation in the best server and adjacent cell relationships in the network.

### Broad areas of use

The R&S® TSMU can be used either as a portable model with a tablet PC and GPS or it can be installed in special test vehicles for high-performance solutions. The specific application determines which system solution is preferred.

The portable model with tablet PC (FIG 1) is ideal in all cases where flexible use either indoors or outdoors is required. The R&S® TSMU and a controller allow convenient measurements in buildings and a series of vehicles.

When installed in a briefcase together with the controller and test mobile phones, the R&S® TSMU can be moved as frequently as needed, making it ideal for use in vehicles and for quasi-stationary measurements indoors.

A common application is the integration of the analyzer into 19" racks of drive test expert systems, where several instruments – e.g. for simultaneous measurements in GSM and UMTS networks – are interlinked and combined with a large number of test mobile phones and test receivers.

The sandwich design of the scanner also allows installation in robust autonomous systems (e.g. in the trunk of taxis).

### ... and the tried-and-tested R&S® ROMES software

The extremely flexible and powerful Measurement Software

R&S®ROMES [2], which is used for all coverage measurement systems from Rohde & Schwarz, is part of all applications of the analyzer. This software is used to control one or more R&S®TSMU analyzers, a GPS system and UMTS test mobile phones as well as to display, store and evaluate measurement data (FIGs 3 and 4). R&S®ROMES can be operated easily and intuitively using the convenient tools of the Windows® user interface such as "drag and drop". The software is completely modular in design, and any technology or device driver can be added by loading and configuring it. This concept represents a particularly sound investment, because the operating philosophy remains the same while the software can be updated to keep pace with new mobile radio generations.

## Summary

Rohde & Schwarz is setting new standards in coverage measurement with its universal UMTS Radio Network Analyzer R&S®TSMU. The intelligent combination of the instrument with test mobile phones enables maximum information to be determined from the air interface, making complicated tasks in mobile radio networks much easier. The R&S®TSMU is leading the way in the areas of network planning, network setup, optimization, quality assurance and service.

Wolf-Dietrich Seidl; Otmar Wanierke

\* The Bluetooth word mark and logos are owned by the Bluetooth SIG, Inc. and any use of such marks by Rohde & Schwarz is under license.

More information and data sheet at  
[www.rohde-schwarz.com](http://www.rohde-schwarz.com)  
 (search term: TSMU)



### REFERENCES

- [1] PN Scanner R&S®TS5K51C – Turbo for UMTS network optimization. News from Rohde & Schwarz (2002) No. 176, pp 4–9
- [2] Coverage Measurement Software R&S®ROMES3 – Acquisition, analysis and visualization of data in coverage measurements. News from Rohde & Schwarz (2000) No. 166, pp 29–32

### Condensed data of the R&S®TSMU

#### Frequency

Frequency range	100 kHz to 3 GHz
Frequency stability (GPS-synchronized)	0.01 ppm
Time stability (GPS-synchronized)	10 <sup>-11</sup>
Analog IF bandwidth (–3 dB)	4.4 MHz

#### Scanner

Synchronization time (high dynamic mode)	
12 PN codes	90 ms
Synchronization time (high speed mode)	
5 PN codes	10 ms
Code power measurement (high speed mode)	–116 dBm to –20 dBm
(high dynamic mode)	–124 dBm to –20 dBm
Dynamic range	
(high speed mode)	20 dB
(high dynamic mode)	29 dB
Level uncertainty (–12 dB $<E_c/I_0 < 0$ dB)	<1.5 dB
Adjacent channel rejection	>65 dB; typ. >70 dB

#### General data

Connections	2 × FireWire IEEE 1394, 6-pin, 400 Mbit/s RF IN, N female, 50 Ω RS-232-C DC IN, 9 V to 18 V DC PULSE IN, BNC, GPS PPS PULSE IN/OUT, BNC distance trigger SMARTCARD port for compact flash cards with 256 Mbyte to 2 Gbyte
Temperature range	+0°C to +45°C
Vibration	40 g shock spectrum
Quality standard	ISO 9000
Operating voltage	9 V to 18 V DC (<1 A at 12 V)
Dimensions (W × H × D)	150 mm × 80 mm × 170 mm
Weight	1.5 kg

## Minimizing measurement uncertainties

# Why Rohde & Schwarz test systems are so exacting

*"I wonder if I can trust you.*

*But then, uncertainty is part of life's*

*fascination, isn't it?"<sup>1)</sup>*

**Uncertainties in one's personal life may be fascinating for some people, but in test and measurement they are totally out of place. This applies especially to conformance test systems from Rohde & Schwarz: For these systems, maximum measurement accuracy is a must (FIG 1). And because determining the measurement uncertainty of such test systems is a complicated and time-consuming process, Rohde & Schwarz tackles this task using sophisticated methods and specially developed software that allows precise, reproducible analysis of the measurement uncertainty.**



43476/2

**FIG 1** Test System R&S® TS 8950 GW for conformance tests of GSM/WCDMA mobile phones. The test system's ability to perform such high-precision measurements is the result of sophisticated calibration methods and software specially developed by Rohde & Schwarz.

## Requirements to be met by conformance test systems

Users of conformance test systems need to know the following:

### 1. What is the overall measurement uncertainty of the test system?

Above all, the test system must meet the requirements defined by 3GPP (3rd Generation Partnership Project) for GSM [1] and WCDMA [2]. Furthermore, users must have detailed knowledge of the measurement uncertainty so that the

measurement results can be correctly interpreted. For example, a measurement uncertainty of 0.1 dB with a confidence of 95% means there is a 95% probability that the true value is within  $\pm 0.1$  dB of the measured value.

### 2. Are the specified measurement uncertainties documented?

In order for test houses to receive accreditation, they must provide documentation confirming the specified measurement uncertainties.

1) Baron Frankenstein, alias Dr Stein, speaking to his assistant (from the film "The Revenge of Frankenstein" by Terence Fisher (1958)).



To answer these questions, Rohde & Schwarz has developed special software packages which it uses to analyze and document the measurement uncertainty of its test systems. The documentation of the results comes with the respective system, but the software is only for Rohde & Schwarz's internal use.

## How measurement uncertainty is minimized

At the heart of a conformance test system is a complex switching unit that automatically connects the measuring equipment with the DUT via different measurement paths and enables reliable measurements. For each test case, a calibration process is performed to eliminate or reduce the effects that can adversely influence the accuracy of the power level measurement on the DUT. Calibration is performed for the following purposes:

- ◆ To eliminate the attenuation of the switching unit
- ◆ To reduce the absolute level uncertainty of signal generators or power meters (e.g. spectrum analyzers) by referencing to a power-meter standard
- ◆ To eliminate matching pairs of internal mismatches and thereby reduce the overall measurement uncertainty caused by mismatches in the system (example, see box at right)

One of the objectives in the design of test systems is to use appropriate circuitry and calibration techniques to reduce the mismatch that would be caused by directly connecting a DUT. This is achieved, for example, by means of attenuators and a sophisticated calibration process specially designed for each test case.

In addition to the measurement uncertainties directly associated with the calibration process, there are several other

## Measurement uncertainties caused by mismatches partially cancel each other out

A test case uses a number of measurement paths for calibrating and measuring the DUT. In a well configured test system, the overall mismatch uncertainty in a test case is considerably less than the uncertainty in each individual measurement path of the test case. This is achieved by finding matching pairs of mismatches which then cancel each other out.

In the example below, the attenuation of the component E is determined. By using a simple calibration process without DUT (measurement path 1) and subsequently measuring the DUT (measurement path 2), the two largest known contributions to the mismatch uncertainty are eliminated: the interaction between the signal generator (A) and the 10 dB precision attenuator (B) and the interaction between the power meter (D) and the 10 dB precision attenuator (C).

### Definitions

**Measurement path:** path between the generator and the power meter

**Mismatch uncertainty contribution:** interaction between two components on the path:

$$\text{Mismatch contribution (standard deviation)} = \frac{|\Gamma_{\text{generator}}| \times |\Gamma_{\text{load}}| \times |S_{21}| \times |S_{12}| \times 100}{\sqrt{2} \times 11.5} \text{ dB}$$

**Overall mismatch uncertainty:** root sum square of the remaining mismatch contributions

### Eliminating the matching pairs of mismatches

Example:

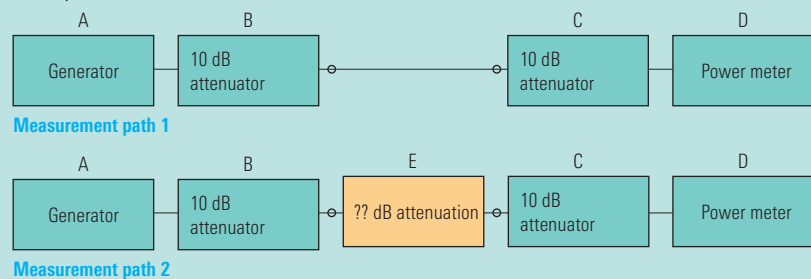

### Mismatch uncertainty contributions

**Measurement path 1:**

AB, BC, CD, ABC, BCD, ABCD

**Measurement path 2:**

AB, BE, EC, CD, ABE, BEC, ECD, ABEC, BECD, ABECD

**Eliminated contributions:** AB and CD

**Combined mismatch uncertainty =**

$$\sqrt{(BC)^2 + (BE)^2 + (EC)^2 + (ABC)^2 + (BCD)^2 + (ABE)^2 + (BEC)^2 + (ECD)^2 + (ABCD)^2 + (ABEC)^2 + (BECD)^2 + (ABECD)^2}$$

**Note:** The contribution ABCD shows the interaction between A and D (generator and power meter). B and C are elements of the signal path.

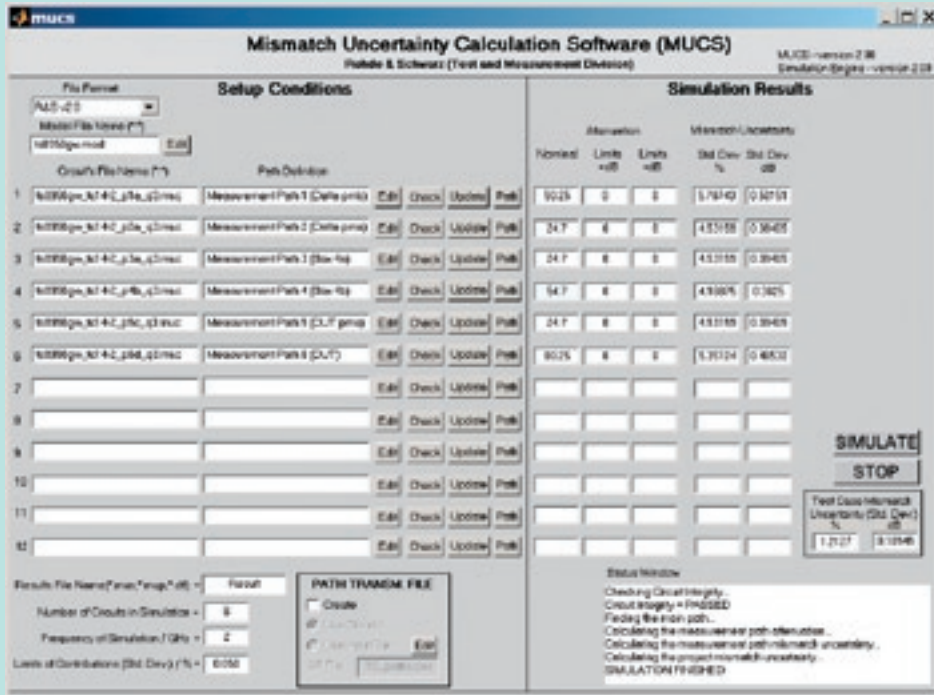
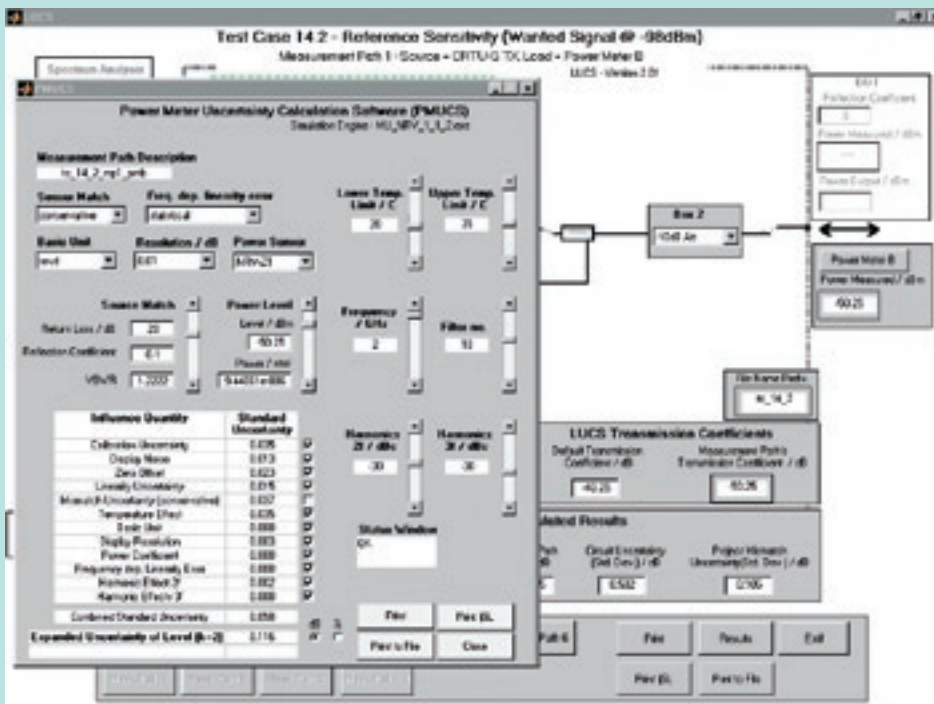

FIG 2 MUCS calculates the attenuation and the mismatch uncertainty for each measurement path of a test case. Subsequently it eliminates the matching mismatch contributions and determines the overall mismatch uncertainty (i.e. the “test case mismatch uncertainty”).

FIG 3 The precision of the power measurement is an important factor in analyzing the test case measurement uncertainty. PMUCS calculates the uncertainty from the simulated insertion loss of the measurement path and the settings of the source.



▶ effects that influence the measurement result, including repeatability and frequency interpolation of the signal generator.

Taking all these measurement uncertainties into account when analyzing a test case is a difficult and time-consuming task. Rohde & Schwarz has therefore developed different software packages for this purpose.

### Special software packages from Rohde & Schwarz

#### Mismatch Uncertainty Calculation Software (MUCS)

MUCS (FIG 2) determines the measurement uncertainty in conformance test systems caused by mismatches according to ETSI specification [3, 4]. The software simulates the circuit and analyzes the circuit description of the conformance test system. This description contains hundreds of components, most of which belong to the signal switching and conditioning unit (SSCU).

The “test case mismatch uncertainty” represents the residual mismatch measurement uncertainty for this test case which could not be eliminated by the calibration process.

#### Power Meter Uncertainty Calculation Software (PMUCS)

PMUCS (FIG 3), which is an interface to the R&S®NRV-Z measurement software [5], was developed by Rohde & Schwarz for calculating the measurement uncertainty of power meters.

#### Level Uncertainty Calculation Software (LUCS)

LUCS calculates the overall power level measurement uncertainty by combining mismatch, power meter and other uncertainties. It features a graphical user interface (FIG 4) that visualizes the measurement paths and set-up condi-

tions in a test case. It is thus possible to compute the power at the power meters, based on the simulated attenuation and the generator output power. The software also displays the simulated test case mismatch uncertainty.

FIG 5 shows how LUCS lists measurement uncertainties caused by power meters, mismatches and various other sources, and makes an overall computation of the power level uncertainty at the measurement output.

## Summary

The software packages provide a systematic and innovative means of calculating power level measurement uncertainties in complex test systems. A complete and accurate analysis can be performed in a fraction of the time it would take using conventional methods. Comprehensive documentation of the measurement uncertainties is ensured.

Michael Haug; David Ryall

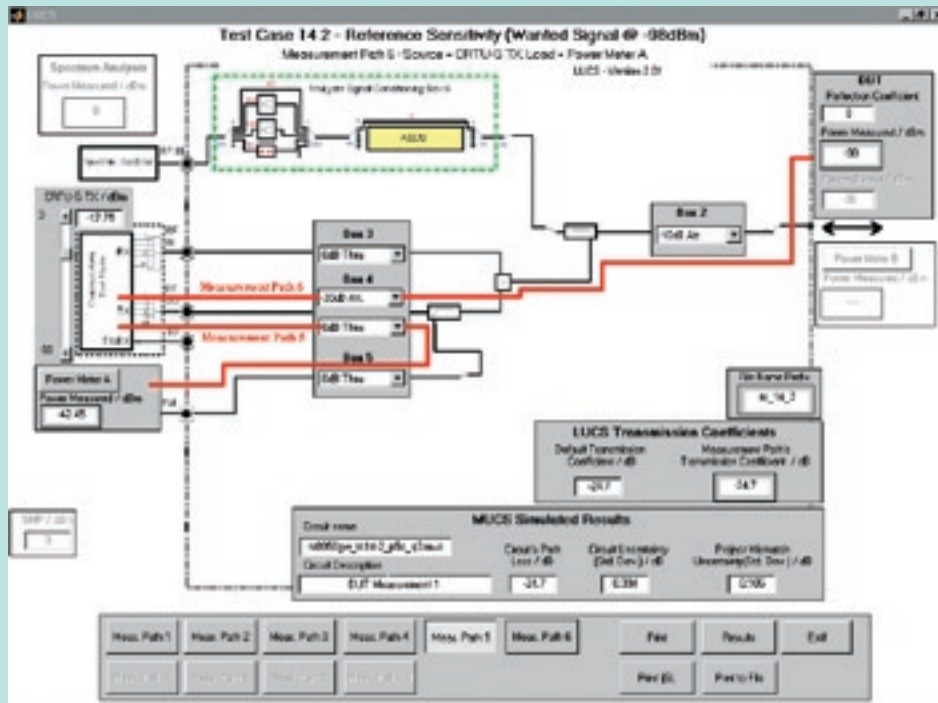
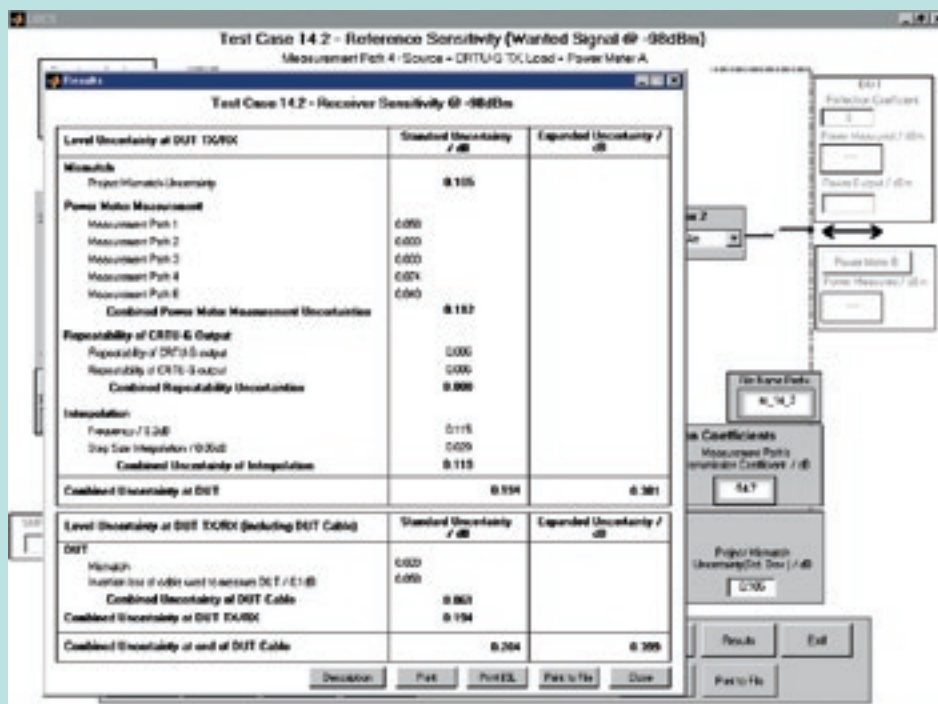

FIG 4 The graphical user interface of LUCS shows the settings for each measurement path of a test case.

FIG 5 The results page in LUCS presents the calculated measurement uncertainties. The results are updated automatically if the test setup is changed.



More information and application notes at [www.rohde-schwarz.com](http://www.rohde-schwarz.com)

### REFERENCES

- [1] 3GPP TS 51.010-1 V5.0.0 (2002-09)
  - [2] 3GPP TS 34.121 V3.9.0 (2002-06)
  - [3] ETSI TR 100 028-1 V1.4.1 (2001-12)
  - [4] ETSI TR 102 273-1-1 V1.2.1 (2001-12)
  - [5] Application Note 1GP43 from Rohde & Schwarz (Program for Measurement Uncertainty Analysis with Rohde & Schwarz Power Meters)
- ◆ International Standards Organization, "Guide to the expression of uncertainty in measurement" (GUM) 1995, ISBN 92-67-10188-9
  - ◆ Calculating measurement uncertainty of conformance test systems for mobile phones. News from Rohde & Schwarz (2000) No. 166, pp 26–28
  - ◆ Johnson, R. A., "Understanding Microwave Power Splitters". Microwave Journal, Dec. 1975, pp 49–56

## Universal Radio Communication Tester R&amp;S® CMU200

# Handover scenarios in GSM systems

**Modern mobile radio systems without handover functionality are inconceivable. The capability to hand over a mobile phone from a UMTS system to a GSM system, for example, is a basic prerequisite for the economic success of UMTS. It is the only way to guarantee UMTS customers full coverage from the start.**

## Intracell handover

The easiest type of handover is intracell handover where either the physical channel or the associated timeslot configuration is changed. This may become necessary if the connection on a physical channel is impaired. To evaluate connection quality, the mobile phone continuously transmits the measured RXLev (receive level measured by the telephone) and RXQual (bit error ratio determined) values to the base station.

If the base station wants to hand over the telephone to another physical channel, all it needs to do is to inform the telephone about the new channel number and the new timeslot configuration. The telephone changes directly to the new

channel and is able to maintain both its previous settings for timing and the base station parameters.

Intracell handover is also possible between different GSM bands. Thus, a GSM cell in the 900 MHz band is quite able to use voice channels in the 1800 MHz band, which, by the way, is an enormous stress factor on the mobile phone since it is constantly required to switch the frequency bands: In addition to the voice connection in the 1800 MHz band, it must also cyclically analyze the BCCH information in the 900 MHz band. This "stress" on the mobile phone and the high performance speed make this handover version the favoured test method in production.

**FIG 1** The GSM neighbour cell list (BA list) of the R&S® CMU200 is user-editable. Up to 16 random channel numbers from any GSM band can be entered. The tester allows convenient and customized definition of the neighbour cells. The WCDMA neighbour cell can be defined in the 3G neighbour cell description.

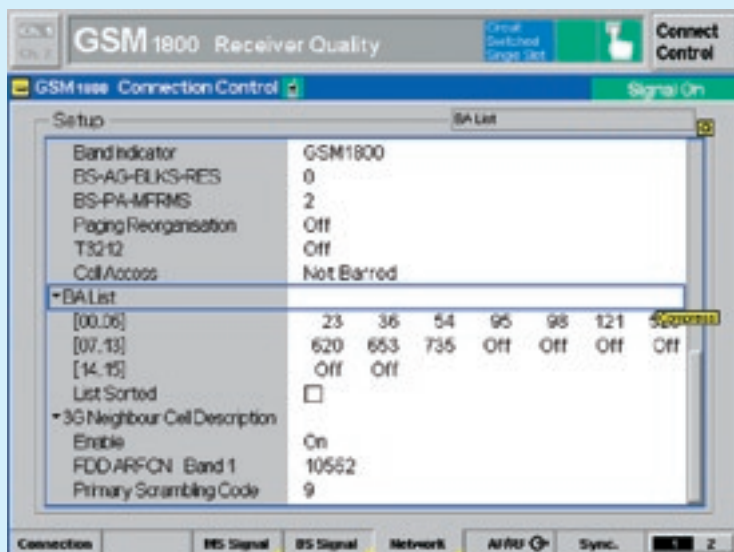

**FIG 2** The mobile phone cyclically determines the receive level on the RF channels listed in the neighbour cell list. The six most powerful RF channels are transmitted from the mobile phone to the base station. The R&S® CMU200 clearly displays these measurement results of the mobile phone.

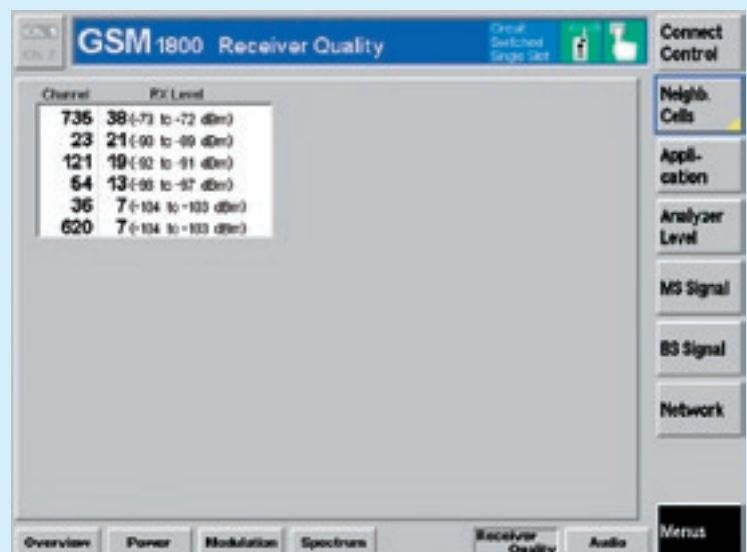

## Inter-cell handover

If the mobile phone moves from one cell to another during a call, it must be handed over to the new cell. If the neighbour cell is time-synchronous with the current cell, the base station is able to effect a finely synchronized intercell handover. In this case, the mobile phone is transmitted on the new physical channel in the neighbour cell. Moreover, the mobile phone must be informed about the vital parameters of the new cell.

The mobile phone then optionally transmits four access bursts on the new channel. Compared to the normal bursts, these are shortened which is why they cannot cause interference with other calls even if the timing is slightly incorrect. If necessary, timing is corrected in a next step and the call continued.

If the two cells with time offset are asynchronous, the base station will effect a pseudo-synchronized or presynchronized intercell handover. This handover is similar to the finely synchronized intercell handover, but differs in that the mobile phone is provided with information about the time offset. Usually, however, a non-synchronized intercell handover takes place. In this case, the mobile phone transmits up to 64 access bursts on the new channel by means of which the new base station determines the timing and hands it over to the mobile phone. The mobile phone then reestablishes the call connection with the correct timing.

The base station requires the mobile phone's help in order to know the new cell to hand it over to. By means of the neighbour cell list, the base station informs the mobile phone about the RF channels for the BCCH that are used by the neighbour cells. The mobile phone now cyclically measures the RF level on these channels and transmits the measurement results to the base sta-

## Handover with the R&S® CMU 200

The GSM signalling option of the Universal Radio Communication Tester R&S® CMU 200 makes it possible to perform intracell handover. It can use physical channels from all GSM bands. The problem of ambiguous channel numbers in GSM 1800 and GSM 1900 has also been solved in the R&S® CMU 200 by implementing the band indicator in accordance with the 3GPP standard. To perform neighbour cell measurements, the tester features user-definable lists for the GSM neighbour cells (FIG 1) and for the UMTS cells. It also outputs the receive levels of the GSM neighbour cells as measured by the mobile phone (FIG 2). In addition to the GSM intracell handover, the R&S® CMU 200 also features blind handover from WCDMA to GSM.

tion. Based on this information, the base station determines the point in time at which the mobile phone is handed over to which cell. Changing the physical channel both for the call and for the BCCH information is key to intercell handover.

## Intersystem handover

If the mobile phone leaves a cell and no new cell can be found in the same system, the base station can hand over an appropriately equipped mobile phone to a cell in another system. These intersystem handovers are highly complex because two technically disparate systems must be combined with each other. Basically, there are two handover options from WCDMA to GSM:

In the case of **blind handover**, the base station simply transmits the mobile phone with all relevant parameters to the new cell. The mobile phone changes "blindly" to the GSM cell, i.e. it has not yet received any information about the timing there. It will first contact the transmitted BCCH channel, where it tries to achieve the frequency and time synchronization within 800 ms. Next, it will switch to the handed-over physical voice channel, where it will carry out the same sequence as with the non-synchronized intercell handover.

For the second type of handover from WCDMA to GSM, the **compressed mode** is used within the WCDMA cell; in this mode, transmission and reception gaps occur during the transmission between base station and mobile phone. During these gaps, the mobile phone can measure and analyze the nearby GSM cells. For this purpose, the base station, similar to the GSM system, provides a neighbour cell list, and the mobile phone transfers the measurement results to the base station. The actual handover in the compressed mode is basically analogous to blind handover.

There is, of course, an intersystem handover from GSM to WCDMA. A special neighbour cell list for WCDMA cells was established in GSM to support this handover.

Rudolf Schindlmeier

More information and data sheet at  
[www.rohde-schwarz.com](http://www.rohde-schwarz.com)  
(search term: CMU 200)



43938/30

### Open Test Platform R&S® CompactTSVP

## Modular test equipment based on CompactPCI/PXI

**The modular R&S® CompactTSVP open test platform provides special cost benefits for T&M applications in the development, production and servicing of telecommunications and automotive electronics.**

### The trend is towards economical platforms suitable for industry

There is a heightened interest in testing departments to configure the required functions in compact units as flexibly as possible so that future requirements can be covered without any need for large additional investments. Moreover, constantly reduced product development times call for powerful, easy-to-operate and standardized software components which can be integrated as reusable modules in a multitude of applications.

Customer requirements, particularly in the telecommunications and automotive electronics sector, emphasize power density and modularity, thus clearly pointing to platform-based T&M equip-

ment that is favourably priced and suitable for industry.

The new R&S® CompactTSVP open test platform from Rohde & Schwarz has been tailored to meet these requirements, offering special cost advantages for T&M applications in the development, production and servicing of telecommunications and automotive electronics. It provides users with a basic modular concept of T&M functionalities and communication interfaces for hardware and software.

The new product line is based on the CompactPCI / PXI and CAN standards already established on the market.

The introduction of the PXI (PCI eXtensions for Instrumentation) standard as

an extension of CompactPCI by the US company National Instruments led to a commonly acceptable path for the technical community to implement measurement functionalities based on an established standard at cost-efficient pricing, featuring well performing modular system components. More than 600 measurement and interface products are currently available for the PXI standard.

### Modular concept for development, production and servicing

The reason behind the development of the new test platform was to provide users with an extremely wide portfolio of T&M methods of modern test equipment. This was accomplished by consistently using open industrial standards such as CompactPCI/PXI and CAN. In addition to Rohde & Schwarz modules, other commercially available hardware components that support these standards can be integrated into the system without any modifications.

The measurement and switching modules are designed for flexible use in the function test of electronics modules. This test can be optionally expanded to a combination test by means of in-circuit testing of components. This is a unique capability based on the CompactPCI/PXI standard.

An enormous problem with conventional CompactPCI/PXI systems is the adaptation to the industrial environment and the DUTs. Even with functional tests, the number of signals to be measured and inputs requiring physical stimulation is constantly increasing. Voltages exceeding 100 V and currents up to 16 A often require DC-isolated measurement, stimulation or switching. The costs incurred for fixture cabling and signal conditioning are just as considerable as the test programming or test equipment itself.

The system concept chosen by Rohde & Schwarz eliminates the above-mentioned adaptation problems, thus setting a new standard in the field of modular test instruments.

### Test platform architecture

The R&S® CompactTSVP base unit (product designation R&S® TS-PCA3) (FIG 1) includes a bus board with the industrial form of the PCI bus – the CompactPCI. The T&M expansions (trigger, synchronization clock) of the PXI standard are supported by 11 of the 14 available peripheral slots (FIG 2).

The CompactPCI standard 32-bit design with its rear transmission module (RTM) concept also makes it possible to route signals via the rear of the test platform without any additional cabling (slots 3 and 4). This is not possible with the PXI (64-bit) version because of the additional

address and data lines (slots 5 to 15). In practice, the rear cabling via RTMs proves to be of advantage whenever a 19" exchangeable fixture is projected on the front.

In the R&S® CompactTSVP, the RTM concept is also used to install DC/DC converter modules that are required for DC-isolated T&M equipment. Since the T&M equipment and the power supply are spatially separated, the test components are not subjected to thermal influence, which in turn improves temperature stability. Moreover, the bit-serial CAN bus is available at slots 5 to 16. All relay-based switching modules are controlled via this internal communication bus.

When activating electromechanical relays, the extremely high data transmission rate of the PCI bus (up to 134 Mbyte/s) is less important when a small number of bits have to be trans-

**FIG 1** The new system platform includes the two base units, R&S® CompactTSVP (FIG) and R&S® PowerTSVP. Flexible configuration allows versatile applications in development, production and servicing.



44043/4

mitted to control the switching path. The clear advantages of the CAN bus are the secured transmission protocol and the easy implementation of the interface on the switching modules. The lower transmission rate (1 Mbit/s) is compensated by means of local processors on the switching modules and command interface control. The measurement modules, on the other hand, use a register interface with the full performance of the bit-parallel PCI bus.

By means of the analog measurement bus (eight lines), signals with voltages of up to 125 V can be flexibly switched between the switching and measurement modules usually without signal conditioning, and rigid cabling can be avoided. It has been designed as a separate and spatially removed bus board and is available at all 16 slots. The special configuration ensures compatibility with standard CompactPCI/PXI modules and prevents interference from the control buses.

The power supply of the system is in accordance with the powerinterface standard (PICMG 2.11 Rev.1.0). In the base unit, a modular power supply unit is fitted at slots A3/A4. A second power supply can be connected in parallel (slots A1/A2) if the need for output current increases, or if a fail-safe switchover unit between redundant components is to be used. As an alternative, these slots can also accommodate a plug-in power supply for the DUT supply.

### The powerful R&S® PowerTSVP switching system

The R&S® PowerTSVP base unit (product designation R&S® TS-PWA3) is used to implement pure switching systems or enhance the number of test points that can be covered. T&M equipment and load circuitry can be separated if necessary because of high voltages or currents. Only CAN-based modules, preferably AF switching modules, are used. The implementation of RF switching systems is also planned as a follow-on development.

The switching system is either controlled via the internal CAN bus interface of the R&S® CompactTSVP or a desktop PC with an appropriate interface. With highly complex systems, a network of up to four R&S® PowerTSVP base units can be implemented simply by connecting the control bus and, if necessary, the analog measurement bus with each other.

As with the R&S® CompactTSVP, the simplified bus concept in the R&S® PowerTSVP is fitted with trigger lines based on PXI technology so that synchronous or event-triggered measurements can also be performed with different instruments (FIG 3).

FIG 2 Bus and slot overview of the R&S® CompactTSVP base unit (product designation: R&S® TS-PCA3).

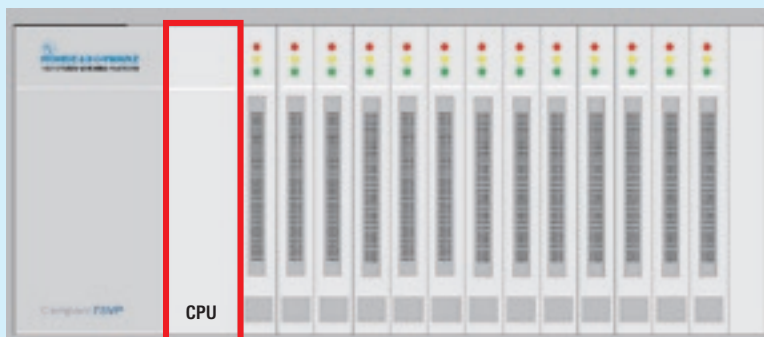

Bus \ Plug-in	A1	A2	A3	A4	1	2	3	4	5	6	7	8	9	10	11	12	13	14	15	16		
CompactPCI																						
PXI																						
CAN bus																						
Analog measurement bus																						
Rear I/O																						
DC/DC rear I/O																						
Power supply																						

FIG 3 Bus and slot overview of the R&S® PowerTSVP base unit (product designation: R&S® TS-PWA3).

Bus \ Plug-in	A1	A2	A3	A4	1	2	3	4	5	6	7	8	9	10	11	12	13	14	15	16
PXI trigger																				
CAN bus																				
Analog measurement bus																				
Power supply																				



FIG 4 Schematic of the module format in the R&S® CompactTSVP plus an example of its use: the R&S® TS-PFG arbitrary waveform generator.

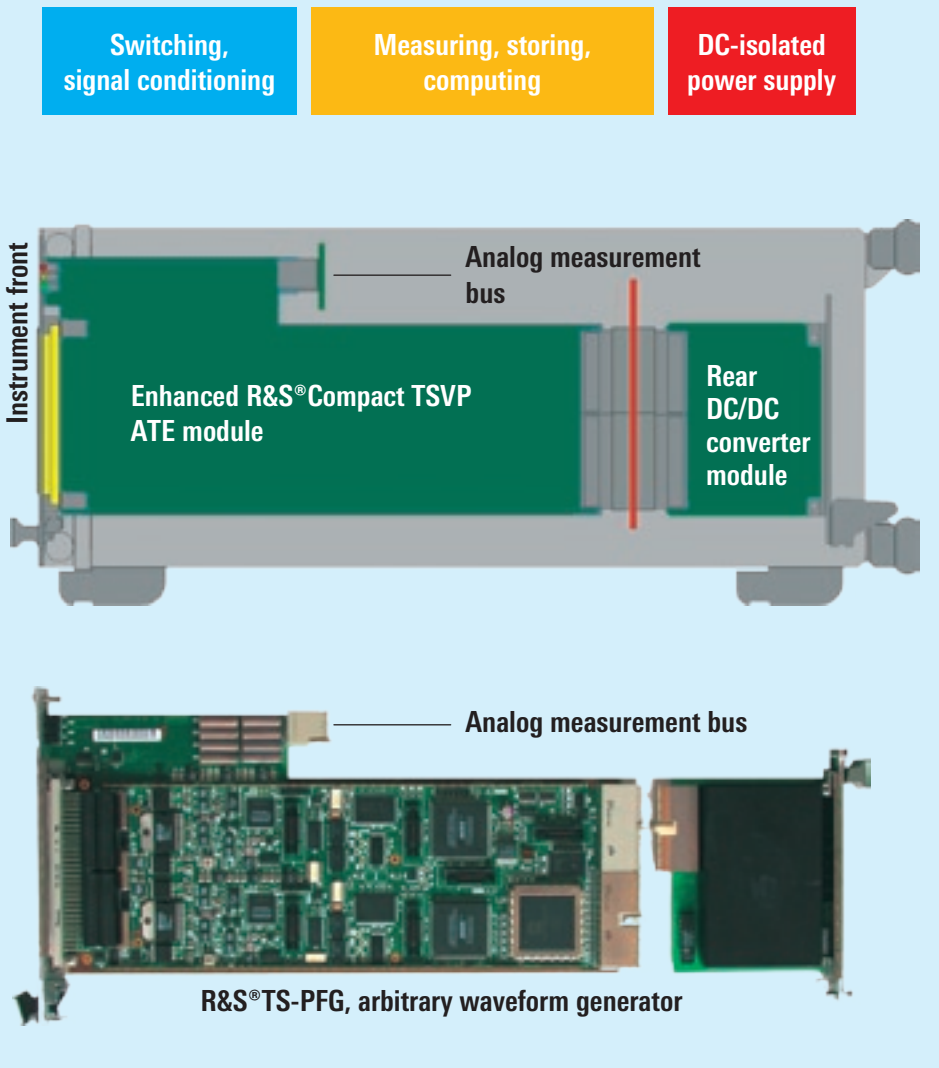

## Module design

The form factor of the R&S® CompactTSVP measurement and switching modules reflects the consistent product philosophy of meeting cross-section requirements in electronics production. Each measurement module allows the primary switching of incoming signals via the front connector plus free access to the internal analog measurement bus. If only a few signals need to be multiplexed for testing a DUT, the multiplexer on the measurement module is often sufficient. If, however, a large number

of channels needs to be handled, multiplexing is carried out via the analog measurement bus and matrix switching modules. As a result, module connection is flexible, which is highly valued in practice, and fixture cabling for these dedicated measurement tasks is simplified.

An important characteristic of the measurement modules is their capability for floating potential measurements or stimulation. They prevent the latent danger of hum pick-ups which are likely to occur with ground-referenced measurements, in particular with longer wiring arrange-

ments. Even measurements in electronic circuits are thus possible without any influence from the T&M equipment.

Isolation of the measurement signal and signal conditioning – e.g. filtering – is directly implemented on the measurement modules of the R&S® CompactTSVP so that most applications do not require any additional cost-intensive subsystems for signal conditioning.

To implement such a circuitry, the module format of PXI modules was elongated by 130 mm compared to the standard Eurocard format (160 mm × 100 mm) and the DC-isolated power supply of the measurement unit located there. A DC/DC converter module specifically developed for this purpose is inserted at the rear of the base unit (FIG 4).

As an extension for industrial use in typical automatic test equipment (ATE) environments, an additional backplane for the analog measurement bus has been integrated; it can be utilized for flexible test signal switching in the chassis between the modules without requiring any additional cables. The signal routing of partially high-impedance analog signals or signals with very low levels must be kept at a physical distance from the “digital highway”, the PCI bus. The same applies to higher voltages. For this purpose, the format of the modules was expanded by an interface for the analog measurement bus. During the measurements the cross-connection of the signals from module to module is generated temporarily via coupling relays to the analog measurement bus.

The analog measurement bus has another important task: It is the basis for an efficient selftest of the modules. The relays of the switching matrix modules in a system can be fully tested by means of resistance measurements. The R&S® TS-PSAM multimeter module that

- ▶ is always provided in functional test systems is intended as internal measuring equipment. It is also used to test measurement and stimulus modules. The comprehensive selftest report allows thorough system diagnostics and makes it easier to locate defective circuitry.

## Modules for the R&S® CompactTSVP

To implement test systems, the following modules from Rohde & Schwarz – in addition to the base units – are available (FIG 5):

- ◆ **R&S®TS-PSC3** System controller as CompactPCI plug-in, currently with 1.2 GHz Pentium III and 256 Mbyte RAM; standard interfaces include USB and Ethernet
- ◆ **R&S®TS-PSAM** Digital multimeter module with a maximum digitization rate of 200 ksamples/s
- ◆ **R&S®TS-PMB** Relay matrix module for signal switching of measurement signals with 90 input channels
- ◆ **R&S®TS-PSM1** Relay module for switching current up to 16 A with integrated current measurement capability via shunts and analog bus
- ◆ **R&S®TS-PDFT** Dynamic digital I/O module with a pattern rate up to 20 MHz, 32 level-programmable digital outputs, 32 digital inputs as well as serial communication interfaces
- ◆ **R&S®TS-PFG** Two-channel arbitrary waveform generator with a maximum pattern rate of 25 Msamples/s, 1 megaword signal memory per channel and a maximum output level of 40 V ( $V_{pp}$ )

The following modules are currently being developed:

- ◆ **R&S®TS-PICT** Complementary module for R&S®TS-PSAM. Combined, the modules allow complete analog in-circuit testing

- ◆ **R&S®TS-PAM** Dynamic signal analysis module with two simultaneous sampling input channels for data acquisition of signals with sampling rates up to 20 Msamples/s

The dynamic measurement and generator modules are particularly outstanding for their floating characteristics and measurements up to 125 V ( $V_{pp}$ ). In addition to the modules from Rohde & Schwarz, the system can also accommodate any standard-conformant CompactPCI/PXI modules with three height units.

## Comprehensive software – ready to go

For convenient test program development, a comprehensive library is available, referred to as a generic test software library (GTSL); it features ready-to-go and fully tested software modules for functional tests, based on the Interchangeable Virtual Instruments (IVI) standard. It includes the entire resources management functionality and the configuration of the modules used in the system, DUT switching as well as all measurement functions of the inte-

FIG 5 Overview of the available components of the R&S® CompactTSVP product line.

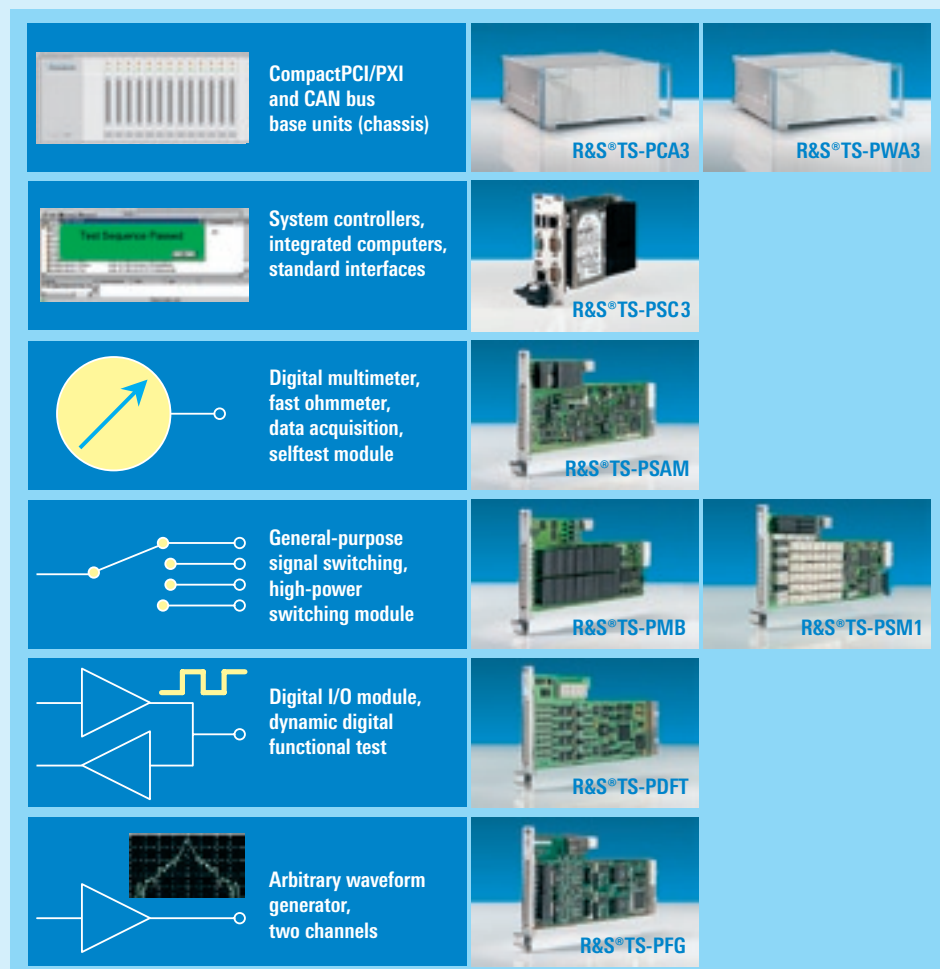

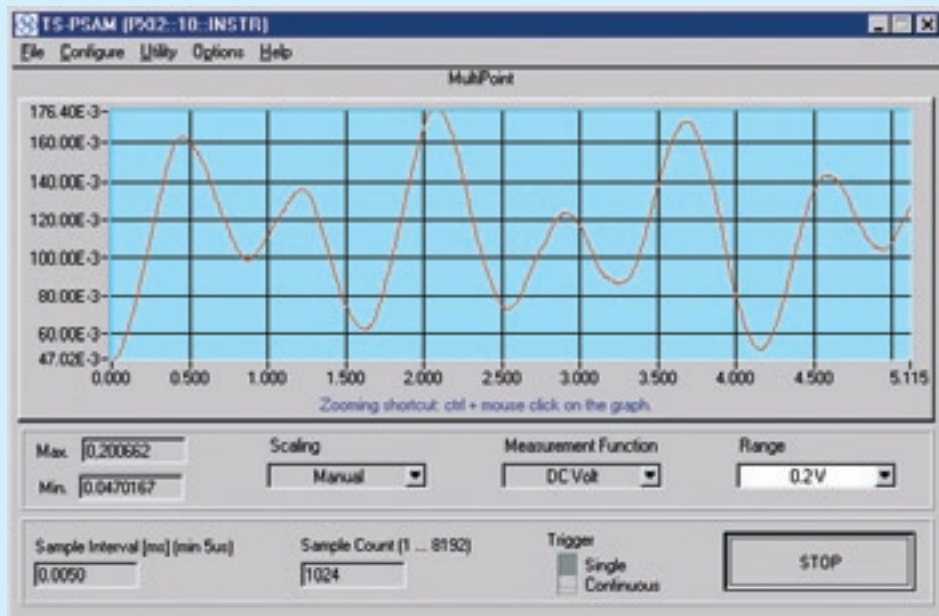

FIG 6 User interface of the Analog Source and Measurement Module R&S®TS-PSAM , displaying an audio signal recorded with 200 ksamples/s.

grated modules. This library allows fast and reliable onsite configuration of test sequences in production and their adaptation to changing requirements.

Moreover, the use of GTSL in test programs significantly facilitates worldwide support for users and systems partners. Owing to the provision of selftest functionalities in GTSL, R&S® CompactTSVP system products can be efficiently verified onsite at any time. Currently, the Windows® NT4 and Windows® 2000 operating systems are supported.

Additional software modules come in handy alongside functional libraries and software drivers. Functional user interfaces (soft panels) are provided for putting a module into operation directly after automatic hardware detection and driver installation (FIG 6). They are used to configure switching paths, the setting of the signal conditioning of the switching and measuring instruments

and of course the measurements, and to instantly perform them. Thus, manual operation of the individual modules becomes possible without having to write a user software program, and putting a test setup into operation becomes considerably easier and takes less time.

### Using the test platform in functional tests

Since T&M basic functionalities and commercially available add-on modules can be combined – in particular for the production of electronics products of average complexity – it is possible to configure a powerful test platform in a single compact instrument. Coming up with a complete application solution usually only requires suitable power supply units for supplying the DUTs or, in the case of high-frequency products, the integration of RF T&M instruments into the system.

The system can be controlled by means of a modular embedded computer. The R&S®TS-PSC 3 from Rohde & Schwarz is a system controller suitable for industry (currently 1.2 GHz Pentium III, 256 Mbyte RAM). Great emphasis was placed on standard interfaces such as Ethernet, USB and RS-232-C.

### Standardized fixture concept

A standardized fixture concept complements the modular design. The measurement and switching modules are to be fit with the easily accessible connectors according to DIN 41612 for cost-efficient signal transfer of a large number of test points. They can be easily wired (e.g. via wire-wrap with needle board fixtures) and are specified for higher voltages.

The counterparts are fitted at the fixture end by means of a robust connector carrier (FIG 7). At the tester end, a wear connector is also mounted by means of a connector carrier onto the fixture frame. The fixture frame is an optional part of the platform and available as a configurable standard component. Moreover, in addition to plug-in RF connections, compressed air or vacuum connections can be set up in the fixture.

### Summary

In everyday use, international development and production sites require T&M functionalities and testing resources that are product-related and thus available at all times to a varying extent and in different combinations. The R&S® CompactTSVP can provide an efficient basis for systems in diverse application scenarios.

In typical test systems such as engine test benches, conformance testers or production test systems, available components cover the common basic func-

tions with regard to test capacity and test depth. Additional functions and numerous interfaces can be seamlessly integrated by means of commercially available components from specialized manufacturers.

The module for analog in-circuit tests which will be available in the future makes it possible to test electronics products for production quality and functionality in one go and with one system.

Daniel Seemann; Michael Grandauer

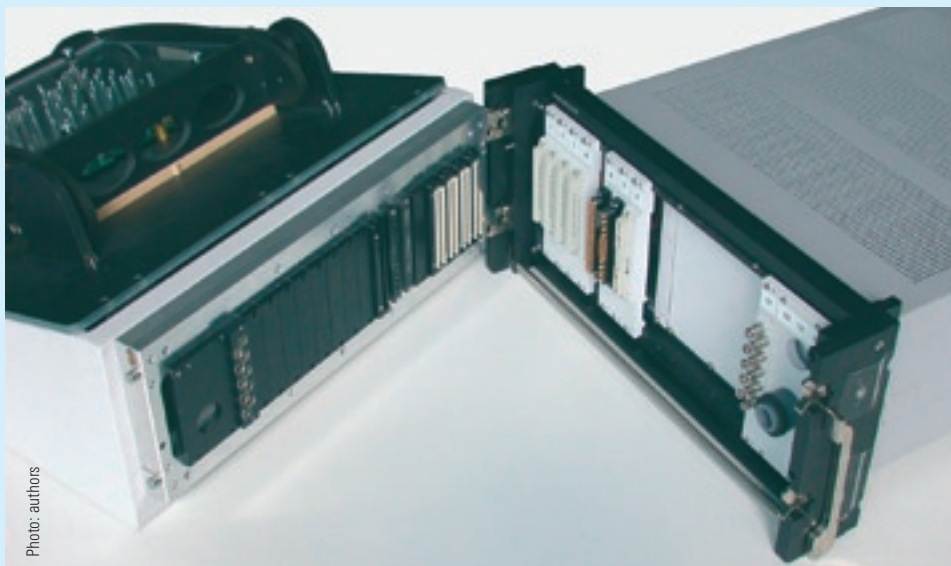

Photo: authors

**FIG 7**  
Functional test fixture (left) and R&S® TS-PCA 3 base unit with mounted R&S® TS-PAD 3 fixture interface.

### Abbreviations

<b>CAN</b>	Controller area network. Bit-serial bus originally developed by BOSCH for networking microprocessor-based control units in vehicles. Has become an automotive standard and, in automation systems, a field bus used all over the world.
<b>CompactPCI</b>	Standardized PCI-based bus system for industrial use.
<b>GTSL</b>	Generic test software library. Comprehensive library of software modules for R&S® CompactTSVP-based test instruments. Includes functions for configuration, DUT connection and test data acquisition – also usable for direct calls from test sequences. Offers high software reusability and flexibility.
<b>IVI</b>	Interchangeable Virtual Instruments. An initiative to standardize driver software for T&M equipment. To allow software control of different manufacturers, the instruments are grouped according to functions, e.g. power supplies, and high-level driver functions are provided.
<b>PXI</b>	PCI-eXtension for Instrumentation. Extension of CompactPCI with T&M features, e.g. synchronization via reference clock 10 MHz, eight dedicated trigger lines.
<b>R&amp;S® TSVP</b>	Test system versatile platform. Platform concept for PC-based T&M equipment with CompactPCI/PXI bus.

More information and brochure at [www.rohde-schwarz.com](http://www.rohde-schwarz.com)  
(search term: TSVP)



The Open Test Platform R&S® CompactTSVP brochure gives an overview of the R&S® CompactTSVP modules including their major specifications and applications.

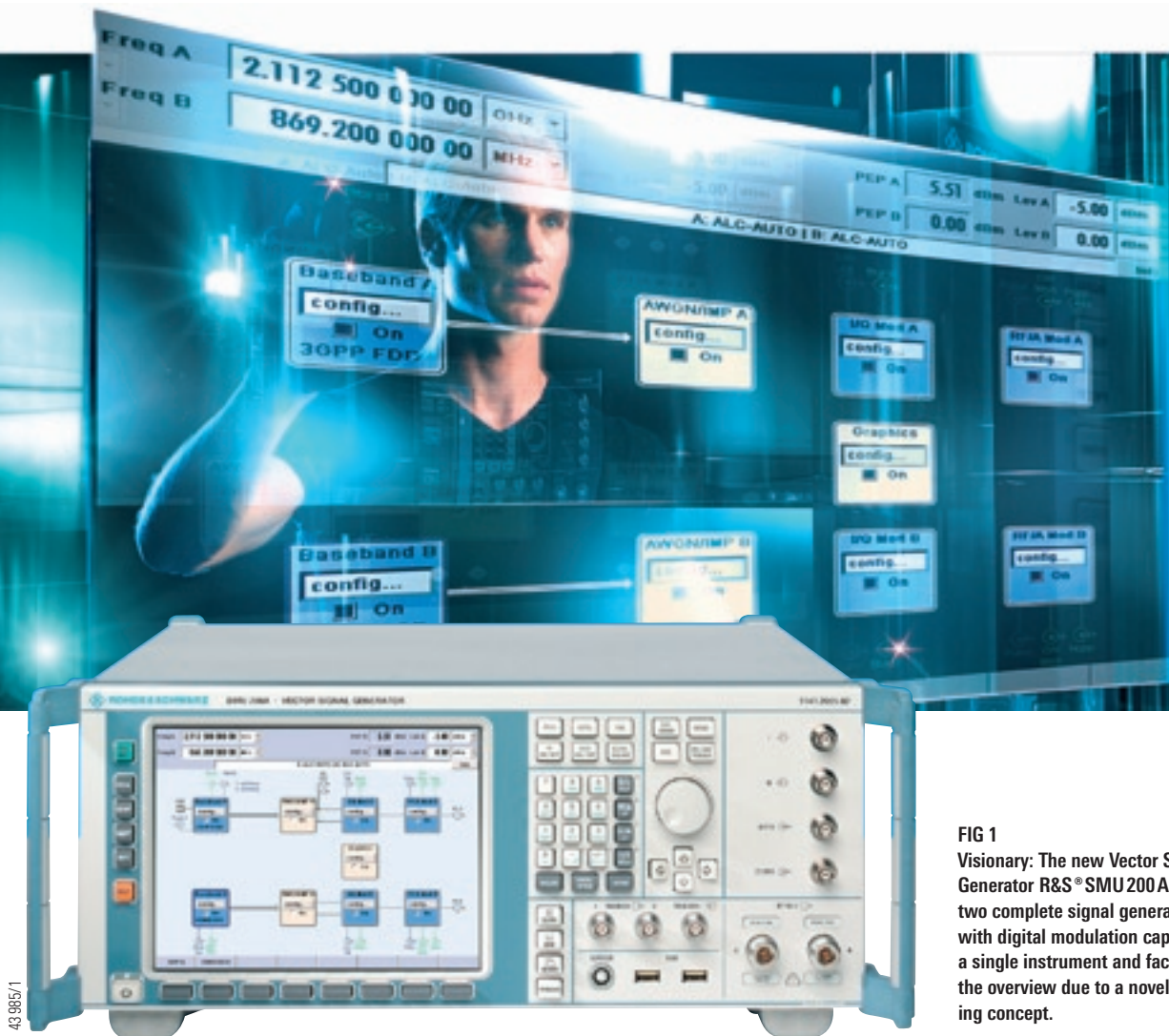

**FIG 1**  
**Visionary:** The new Vector Signal Generator R&S®SMU 200A offers two complete signal generators with digital modulation capability in a single instrument and facilitates the overview due to a novel operating concept.

**An outstanding achievement: The R&S®SMU 200A as the follow-up instrument to the successful Signal Generator R&S®SMIQ excels at flexibility and performance. It is the first high-end generator able to offer two complete signal generators with digital modulation capability in a single instrument.**

## Vector Signal Generator R&S®SMU 200A

# The art of signal generation

### Modular design for user-friendly solutions

The new Vector Signal Generator R&S®SMU 200A is based on a powerful system platform with a fast processor and SVGA colour display (800 × 600 pixels). Occupying only four height units, it offers space for up to two RF paths – and the user is able to choose from four different frequency options (upper frequency limit 2.2/3/4/6 GHz) for the first RF path. In addition, a second RF path with an upper frequency

limit of up to 2.2 GHz or 3 GHz can be installed. The lower frequency limit is 100 kHz for all options. Both RF paths have I/Q modulation capability via the internal baseband section of the generator. The first RF path can also be modulated with external analog I/Q signals.

The baseband section of the R&S®SMU is completely digital and can accommodate up to two I/Q baseband generators. Their output signals can be provided with a frequency offset in the baseband and added as well.

43 985/1

# Application examples: The R&S® SMU200 A with two paths

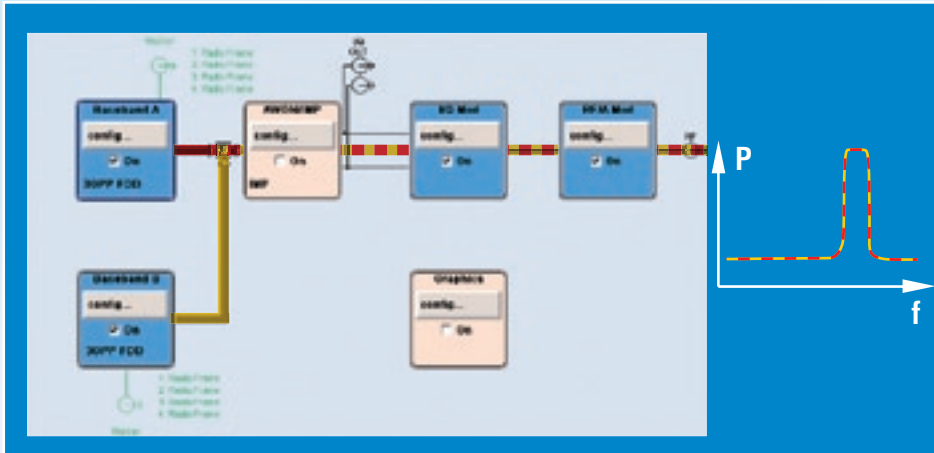

FIG 2

The block diagram on the R&S®SMU display is of key importance to the operating concept. Left, the example of 3GPP transmit diversity, where a base station transmits differently coded signals via two transmitting antennas. An R&S®SMU with two baseband generators is able to simulate this, for example to test the receiver of a mobile phone. Baseband A generates the signal of antenna 1, baseband B that of antenna 2 (each in realtime with channel coding). Since both signals are transmitted on the same RF frequency, only one RF path is required. The yellow/red signal flow in the block diagram of the generator was subsequently added to these examples for clarification purposes.

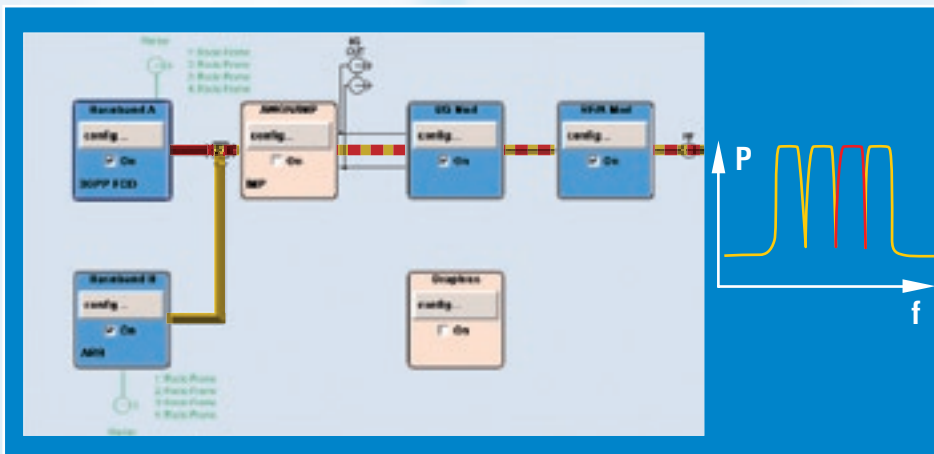

FIG 3

Simulation of the multicarrier signal of a 3GPP base station for receiver tests on mobile stations, where baseband A generates in realtime the wanted signal to be demodulated by the receiver. Baseband B generates a matching multicarrier signal as the background signal by means of its arbitrary waveform generator.

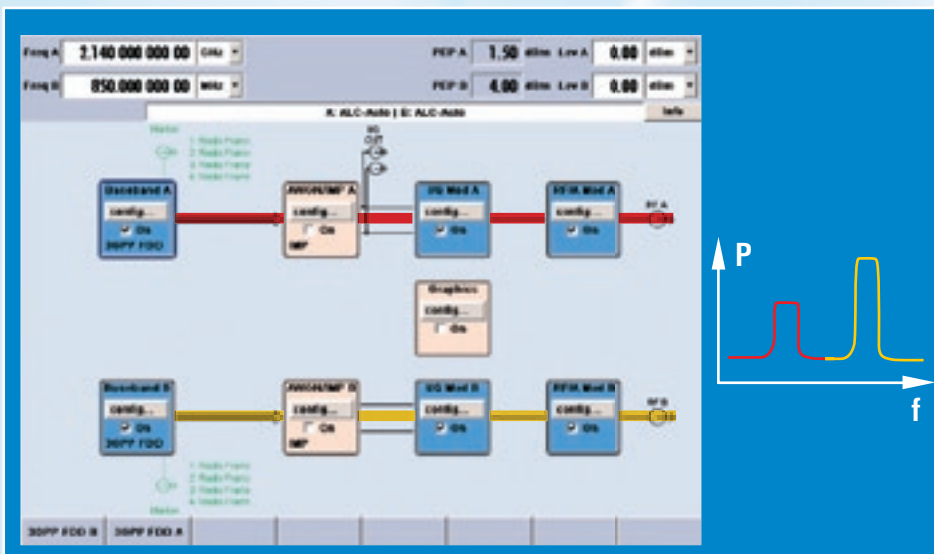

FIG 4

With two RF and two baseband paths, the R&S®SMU simultaneously generates wanted and interfering signals of receiver tests; the interfering signal can, of course, also be modulated. Thus, tests such as adjacent channel selectivity or blocking are feasible with only one instrument.

- The flexible concept with diverse options allows nearly all conceivable versions: from the vector signal generator with external modulation capability with one RF path through to the fully-fledged device with two RF paths. Moreover, most options (e.g. digital mobile radio standards) are software options and easily upgradeable. Users can thus configure devices that are tailored to meet their specific applications and only buy what they really need.

### Two baseband/RF paths open up new applications

Two signal generators in one – a design that saves 50% in space. Both paths open up applications to the R&S®SMU that were so far only feasible with several signal generators, involving enormous effort. If two baseband generators are installed, their output signals can be digitally added and applied to the I/Q modulator of an RF path – if necessary weighted and with an application-specific frequency offset. Owing to an innovative resampling concept, the entire baseband section runs using a common clock, and synchronization is child's play. One baseband generator can also trigger the other one, allowing a defined time offset between the signals. It is thus possible to create complex scenarios that will be required in mobile radio in the future by using just one RF path (for examples, see left page). The maximum bandwidth of the overall signal of 80 MHz is more than sufficient for nearly all applications.

With two RF and two baseband paths, there is almost nothing left to be desired. The generator can also generate signal combinations that largely differ in power and frequency offset, for example a wanted signal and modulated interfering signal for receiver tests. Modulation signals of up to 80 MHz are now possible on each path.

### Ready for 3G and more

The core of an R&S®SMU baseband generator (option R&S®SMU-B10) is a universal coder with DSP and FPGA coprocessor for calculating complex signals in realtime. The generator is thus basically able to generate signals for all common mobile radio standards. The universal coder features ASK, FSK (incl. MSK), PSK (incl. 8PSK EDGE) and QAM (up to 1024QAM) as modulation modes plus all standard baseband filters and coding types. Different PRBS types, user-specific patterns and data lists are provided as internal data sources. It is also possible to apply external data in realtime via the USB interface, the serial or the parallel port.

Moreover, each R&S®SMU baseband generator contains an arbitrary waveform generator (ARB) with a 56 Msample memory depth, thus surpassing even the trustworthy I/Q Modulation Generator R&S®AMIQ from Rohde & Schwarz. Plus, lower oversampling values can be used with each of these ARBs because of the built-in hardware interpolation filter, which again increases the effective memory depth.

Of course, the tried-and-tested Simulation Software R&S®WinIQSIM™ supports the R&S®SMU, too. All standards that can be generated with this software, including WLAN 802.11 (a, b and g), cdma2000 and 3GPP TDD low rate (TD-SCDMA) and high rate, are thus available to users right from the start.

Furthermore, the generator internally provides software options that are tailored to meet important mobile radio standards. To begin with, the 3GPP FDD und GSM/EDGE options are available. Another available option generates CW multicarrier signals as are often required for amplifier tests.

The GSM/EDGE option allows the R&S®SMU to change modulation between GMSK and 8PSK EDGE in realtime and offers all burst types defined in the standard. Plus, in the new framed (double) mode, two different frames can be generated. The number of repetitions of a frame prior to changing to another frame can be set. The generator is thus able to simulate multiframe scenarios, for example an idle burst every 26 frames, or a change of modulation as a function of time in a defined timeslot.

In the digital standard 3GPP, the realtime capabilities and the ARB of a baseband generator are combined so that the generator provides an impressive functionality portfolio. In downlink mode, up to four code channels can be generated in realtime, including channel coding (PCCPCH and up to three DPCHs). All in all, the R&S®SMU simulates up to four base stations with 128 DPCHs each (with control channels). All conceivable scenarios are thus possible, ranging from the standard-conformant reference measurement channel to the simulation of a base station under full load. The orthogonal channel noise simulation (OCNS) defined in the standard is, of course, also available. In uplink mode, the three modes PRACH, PCPCH and DPCCCH with DPDCH can be selected, for mobile station 1 all in realtime and with channel coding. Thus, receiver tests on 3GPP base stations according to TS 25.141 are possible. For more complex scenarios, the generator can simulate up to 67 additional mobile stations. Numerous other functions and comprehensive graphical possibilities such as code domain (FIG 5) or channel graph complement the picture. ►

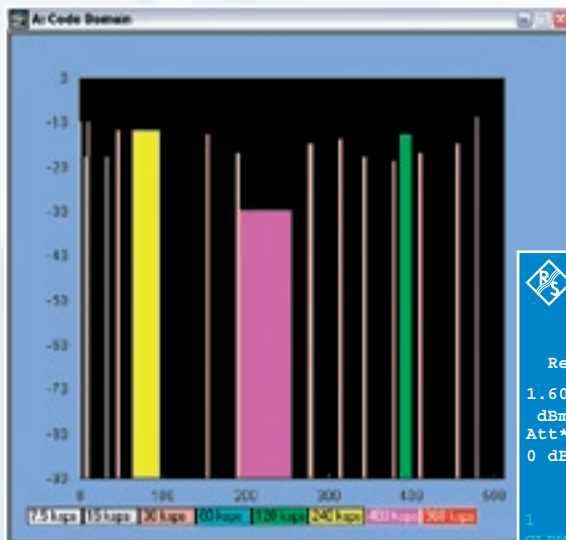

**FIG 5**  
 Left: The code domain display of the 3GPP FDD system in the R&S® SMU.  
 Below: For comparison, the same signal measured by using the 3GPP option in the Signal Analyzer R&S® FSQ.

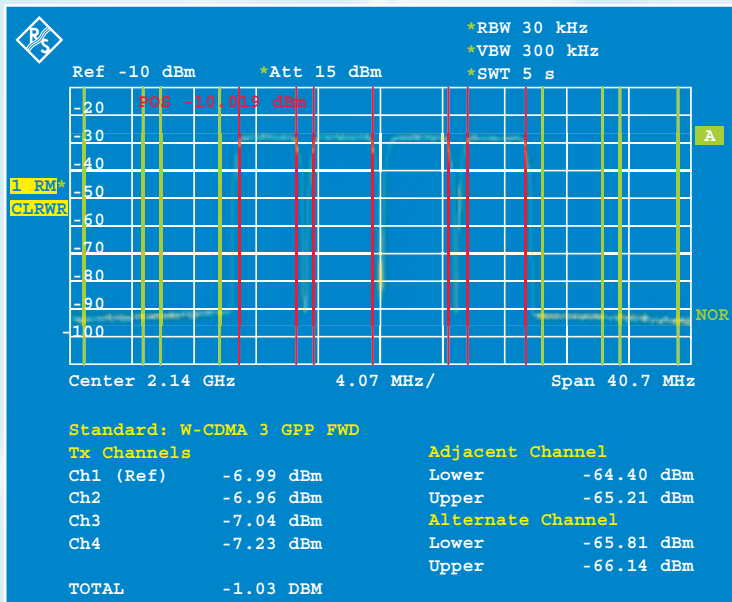
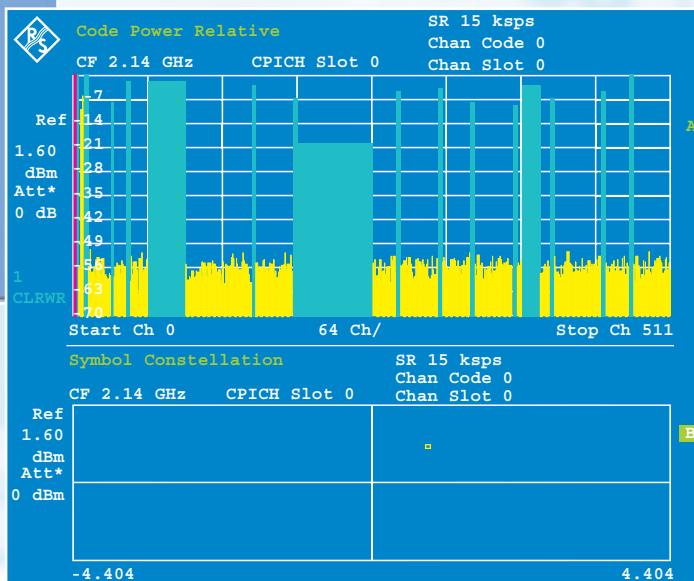

**FIG 6** With a 3GPP signal with four carriers, the R&S® SMU achieves ACLR values of typically 64 dB in the adjacent channel, typically 65 dB in the alternate channel.

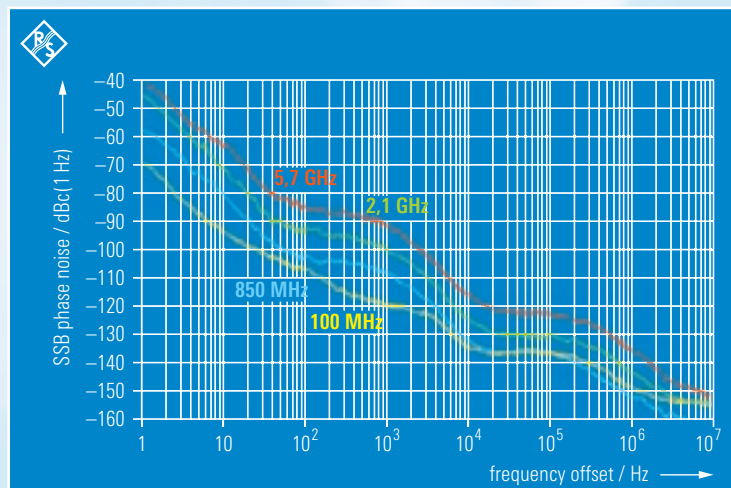

**FIG 7** SSB phase noise of the R&S® SMU for important carrier frequencies (typical values).



- ▶ If required, additive white Gaussian noise (AWGN) or artificial I/Q impairments can be added to the I/Q signals thus generated. For test purposes, a single noise signal can be generated. Modern 16-bit DACs carry out the D/A conversion.

## Outstanding signal quality

Needless to say, the signal quality of the R&S®SMU – a criterion that is still of paramount importance in many applications – is just as impressive. Especially measurements on RF components such as power amplifiers for 3GPP base stations place highly stringent requirements on the T&M equipment used (FIG 8). Here as well, the generator wins out. With a 3GPP test model 1, 64 DPCHs, it achieves ACLR values of typically 70 dB in the adjacent channel and typically 75 dB in the alternate channel. With a 3GPP four-carrier signal, as shown in FIG 6, the generator typically achieves 64 dB in the adjacent channel and typically 65 dB in the alternate channel, thus offering maximum performance for any conceivable signal configurations. At the same time, the vector error of the generated signals is extremely small (for 3GPP typ. 0.3% with 1 DPCH, rms value).

Another important parameter is the SSB phase noise (FIG 7). In this case, the generator typically achieves  $-135$  dBc at 1 GHz (20 kHz offset, 1 Hz measurement bandwidth); to achieve such a value, conventional devices require expensive options. This achieves not only exceptionally small modulation errors with narrowband standards but makes the R&S®SMU ideal for use as an interferer with blocking measurements.

The I/Q modulator used in the generator exhibits an RF modulation bandwidth of 200 MHz which can be fully exploited in the external wideband I/Q mode with external analog I/Q signals.

If the internal baseband section is used, an RF modulation bandwidth of 80 MHz (per installed path) is available. The R&S®SMU is thus ideally prepared for the broadband systems of the future.

A new digital level control ensures high level linearity and accurate repeatability, both important parameters for numerous measurements. With the latter, the generator typically achieves an excellent value of 0.05 dB – even with modulated signals such as for 3GPP. The overall level uncertainty is less than 0.5 dB.

An electronic attenuator ensures wear-free switching in the entire level range. The generator features up to +13 dBm (PEP) in its standard version. By means of the high-power option, the output power can be increased up to +19 dBm (up to +26 dBm in overrange). The

option is installed in parallel with the electronic attenuator so that the latter can still be used in the normal level range.

## Modern intuitive operating concept

The third-generation mobile radio places high demands on the functionality of signal generators. Complex signals, partially with channel coding, must be generated for standard-conformant measurements on base stations or mobile phones. For this reason, Rohde & Schwarz has developed a state-of-the-art operating concept with a graphical user interface for the R&S®SMU. The main element of this concept is the block diagram that visualizes the entire signal flow from baseband ▶

**FIG 8** The R&S®SMU (upper instrument in FIG) sets new standards in signal generation and excels not only in measurements on power amplifiers.

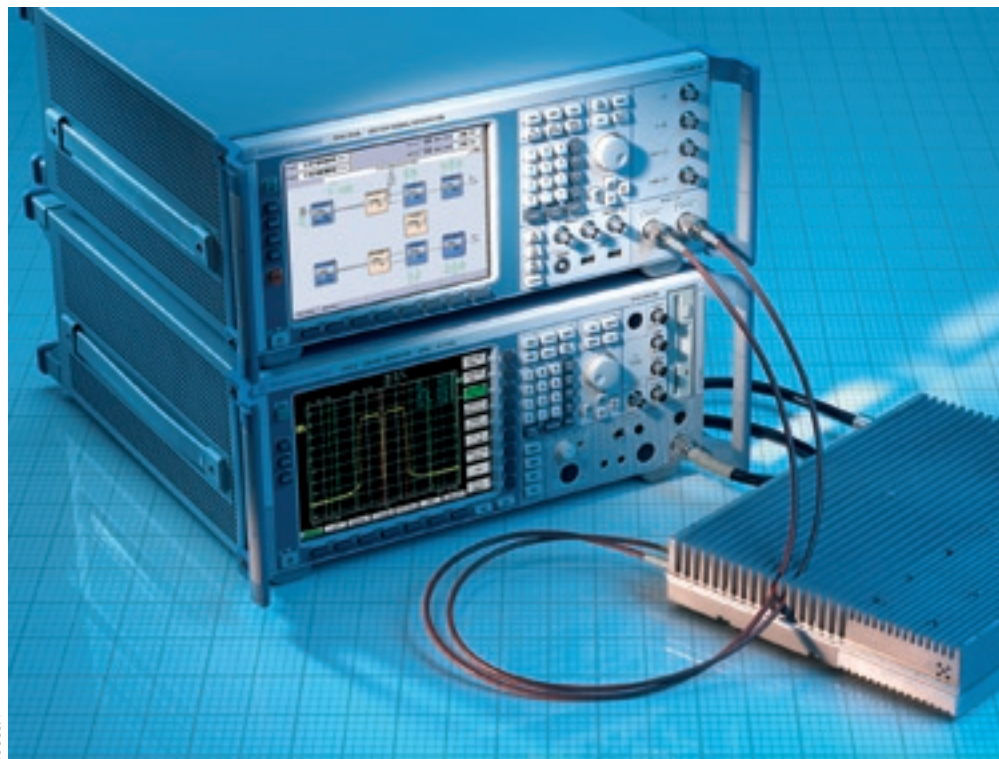

43985/7

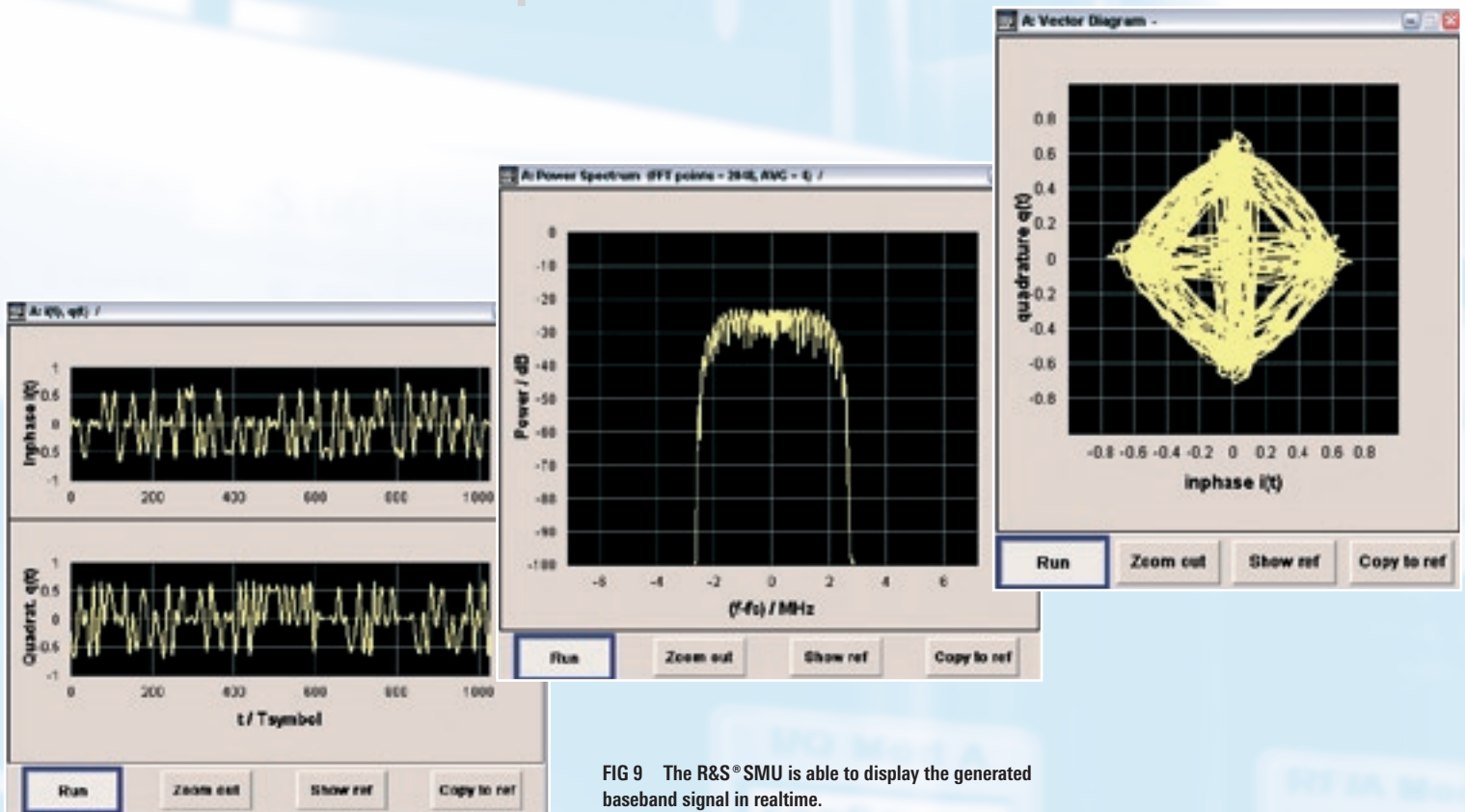

FIG 9 The R&S®SMU is able to display the generated baseband signal in realtime.

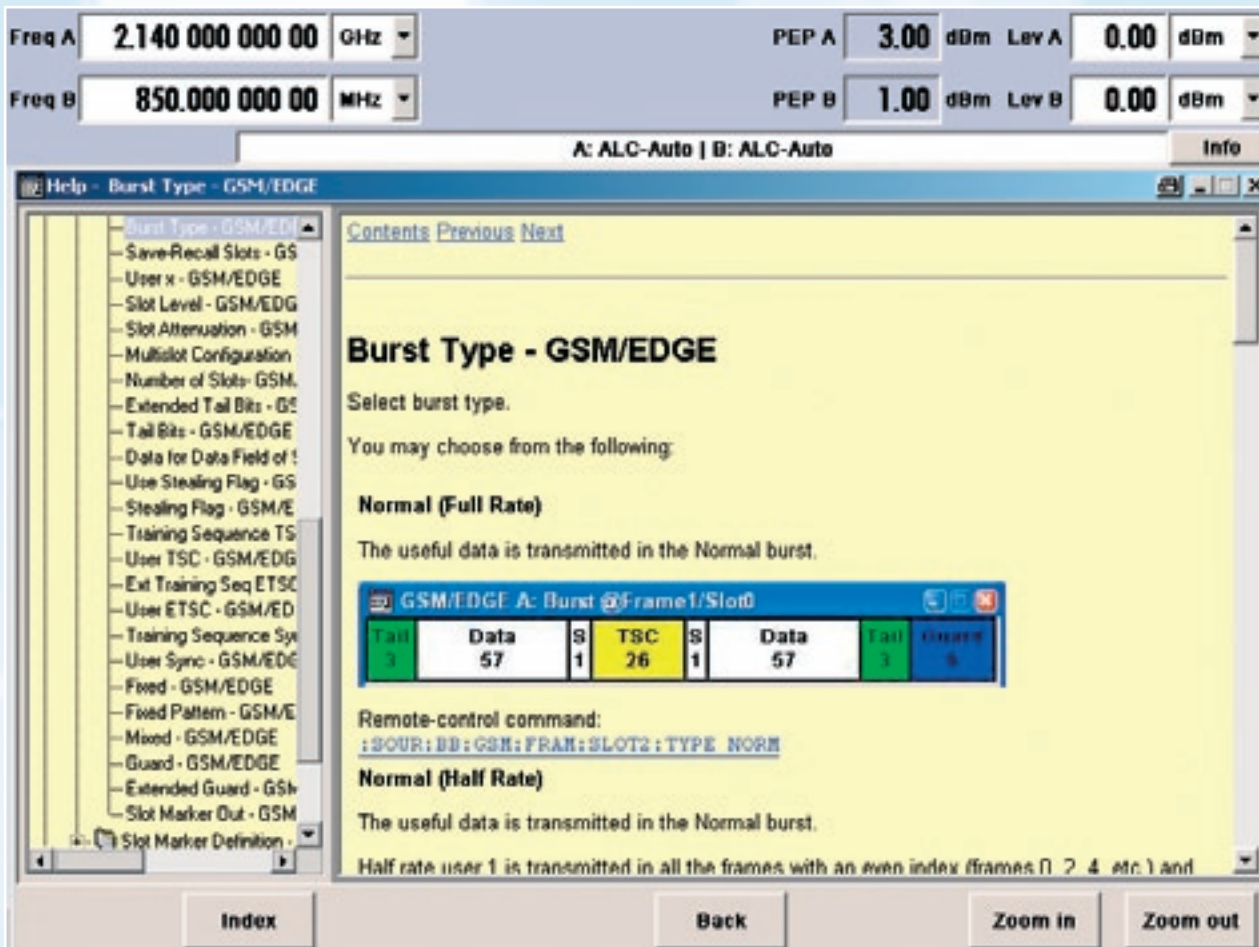

FIG 10 The context-sensitive help includes the entire operating manual and offers full-text search.

► to RF output (FIG 2 to FIG 4) with each block representing a functional unit in the device. The graphical display helps the user to recognize at any time both the active blocks and the point in the signal flow at which a specific parameter is effective. The block diagram also shows other active control signals such as trigger or marker. Submenus are displayed in individual windows, similar to PC programs. The generator can be controlled via the front panel as well as with keyboard and mouse.

The block diagram and in particular its graphical functions are convincing. Owing to its built-in transients recorder, it can display the generated baseband signal in realtime in all common display modes: I(t), Q(t), vector diagram, con-

stellation diagram, frequency spectrum, etc (FIG 9). It is thus easy to verify if the required signal is generated; moreover, an oscilloscope or a signal analyzer to check the I/Q signal becomes superfluous. This concept makes even the generation of the most complex signals child's play – and it's fun to operate the R&S® SMU.

And should the user really need some help, this is also no problem. A simple click on the help key opens the context-sensitive help system with explanations of the selected parameter (FIG 10). It contains the entire operating manual of the generator and offers numerous possible navigations including full-text search, as known from Internet browsers.

Dr René Desquiotz

More information and electronic configuration on the Internet at [www.rohde-schwarz.com](http://www.rohde-schwarz.com) (search term: SMU 200A)



Brochure



Configuration



Specifications

### The main characteristics of the Vector Signal Generator R&S® SMU 200A

- ◆ Two signal generators in one
- ◆ First RF path up to 2.2/3/4 GHz or 6 GHz
- ◆ Second RF path up to 2.2 GHz or 3 GHz
- ◆ Up to two I/Q baseband generators can be installed
- ◆ Baseband signals can be added digitally, also with frequency offset
- ◆ Baseband generator with universal coder for realtime signals and arbitrary waveform generator with 56 Msample for I and Q and four marker bits per sample (256 Mbyte)
- ◆ I/Q modulator with 200 MHz bandwidth
- ◆ Very low SSB phase noise of typically  $-135$  dBc ( $f = 1$  GHz, 20 kHz carrier offset, 1 Hz measurement bandwidth)
- ◆ Outstanding ACLR values of typically 70 dB (3GPP test model 1, 64 DPCHs, adjacent channel)
- ◆ Very short frequency setting times of  $<3$  ms ( $<450$   $\mu$ s in List mode)
- ◆ Electronic attenuator up to 6 GHz
- ◆ High output level up to +19 dBm (+26 dBm in overrange) with high-power option
- ◆ Intuitive operating concept with graphical display of the signal flow (block diagram)

## Vector Signal Generator R&amp;S® SM300

# Wide variety of test signals at an excellent price

## Like the Spectrum Analyzer

R&S® FS300 [\*], the new signal generator is based on the Family 300 platform and has its characteristic design.

The R&S® SM300 offers maximum functionality in a compact unit and excellent specifications at a low price.

## Wide variety of functions

Whether in the development lab, in service or remotely controlled in production, the new R&S® SM300 (FIG 1) is an ideal choice if you need a favourably priced signal source. Despite its low price, this signal generator meets virtually every requirement as regards versatility of application: integrated broadband I/Q modulator, pulse modulator, modulation generator, electronic attenuator and a frequency range from 9 kHz to 3 GHz.

Featuring a 5.4" colour display and a user-friendly operating concept – the set parameters are displayed in a clear-cut block diagram – the generator can be configured fast and conveniently.

## A universal talent

The new member of the R&S Smart Instruments™ family covers all the important frequency bands, e.g. for WLAN, Bluetooth® and EMC measurements. The R&S® SM300 is the first generator in this price category to deliver digitally modulated signals, as required for mobile radio measurements. All that is needed is an I/Q arbitrary waveform generator, for example the R&S® AMIQ, which is connected to the I/Q inputs of the R&S® SM300. The generator's built-in I/Q modulator has a bandwidth of 40 MHz, which means that the instrument covers all common mobile radio

FIG 1 The Vector Signal Generator R&S® SM300, the new member of the R&S Smart Instruments™ family.



R&S  
Smart Instruments™

standards and fully meets the relevant requirements for in-channel measurements.

On top of this, the signal generator offers frequency and level sweeps, versatile analog modulation modes including AM, FM,  $\phi$ M, and high signal quality. This makes the R&S® SM300 a universal tool for all kinds of radio measurements in the lab, in service and in the production test shop. Its frequency range can even be extended down to 20 Hz by means of the AF generator, whose output is next to the RF output.

The built-in squarewave generator and pulse modulator in addition generate bursts with a minimum duration of 100  $\mu$ s. The pulse modulator has a rise time of less than 500 ns, which allows bursts as short as a few microseconds to be generated if an external pulse generator is used. Such bursts are needed in radar applications, for example.

The output level can be set between -127 dBm and +13 dBm in steps of 0.1 dB – an important prerequisite for sensitivity measurements on receivers. This feature is enhanced by the extremely low level uncertainty of the R&S® SM300, i.e. less than 1 dB (for levels  $>-120$  dBm) over the entire specified frequency range, which is achieved by means of complex calibration processes. Compared with generators with higher level uncertainty, the R&S® SM300 thus allows greater tolerances in the test setup without any detrimental effect on total measurement uncertainty. This reduces the costs of test setup as well as the error rate.

As far as signal quality is concerned, the new generator is particularly attractive for its low spurious FM and AM. Typical values are as low as 0.01 % or 3 Hz, respectively, weighted to ITU-T – which can by no means be regarded as standard in this price category. These key fig-

ures, which are important for modulation, make the instrument ideally suited for applications where the transmission characteristics of amplifiers and mixers are to be determined.

## Elaborate design

A synthesizer with only one loop generates RF frequencies in the range 3.8 GHz to 6.8 GHz (FIG 2). To fulfil the stringent requirements placed, for example, on phase noise and frequency resolution, an ASIC developed by Rohde & Schwarz is used that features a fractional divider as well as direct feed of the FM signal into the control loop. The signal obtained is applied to a mixer and converted, with a fixed frequency of 3.8 GHz, to the useful frequency range of 0 Hz to 3 GHz. Compared with signal generation by way of frequency division, this method not only reduces costs since it eliminates the need for dividers and harmonics filters, but also has the advantage that the maximum possible frequency deviation is ensured across the entire frequency range. The advantages of this method are shown by the very low phase noise of the R&S® SM300 at a warranted value of -95 dBc(1 Hz) at a carrier offset of 20 kHz.

The generator concept also allows the easy implementation of a pulse modulator. The signal at the output is switched on and off by switching a 3.8 GHz VCO on and off. This concept offers the advantages of short switching times of less than 500 ns as well as a wide dynamic range. The pulse modulator can be driven either by means of the internal squarewave generator or an external pulse generator. The internal squarewave generator is purely digital with pulse widths selectable between 100  $\mu$ s and 1 s.

The implementation of digital modulation is somewhat more complex. For

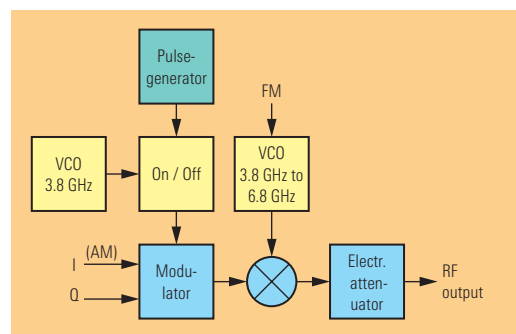

FIG 2 Block diagram of the R&S® SM300.

this, an I/Q modulator is needed, which becomes more expensive or more restricted with respect to technical data as the range it covers widens. The I/Q modulator of the R&S® SM300 operates at a fixed frequency only, which reduces broadband requirements, and for the first time allows excellent modulation characteristics to be achieved at an unprecedented price.

Due to the use of a finely stepped electronic attenuator, the new generator even withstands continuous operation under the harshest conditions in production. On top of this, the generator comes with an excellent VSWR of  $<1.6$  (9 kHz to 3 GHz) – an important prerequisite for low level uncertainty at the DUT.

## I/Q modulator

The R&S® SM300 is the only signal generator in this price range that offers as standard a built-in I/Q modulator and thus opens up, as an entry-level model, the world of digitally modulated signals such as used in digital mobile radio or in WLANs. The I/Q signals required as an input to the modulator are supplied, for example, by the I/Q Modulation Generator R&S® AMIQ from Rohde & Schwarz or, alternatively, by the Function/Arbitrary Waveform Generator R&S® AM300 (FIG 5), which will soon be available as a new member of the Family 300. ▶

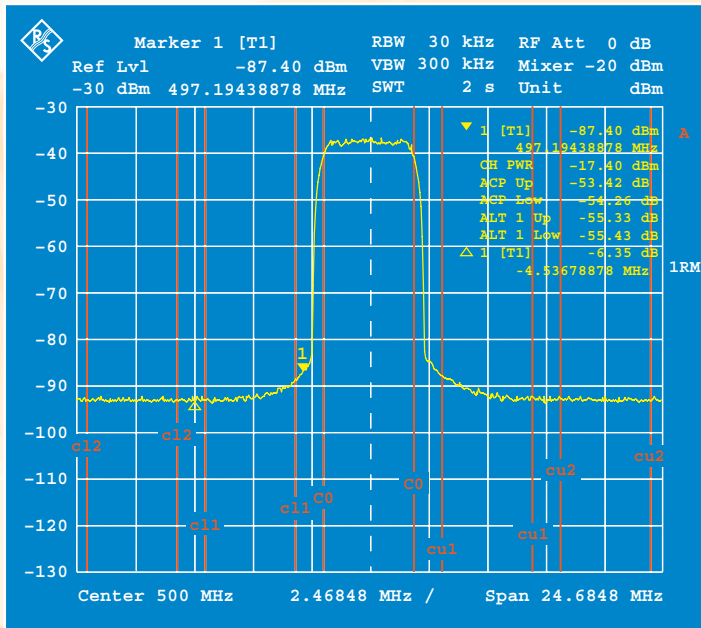
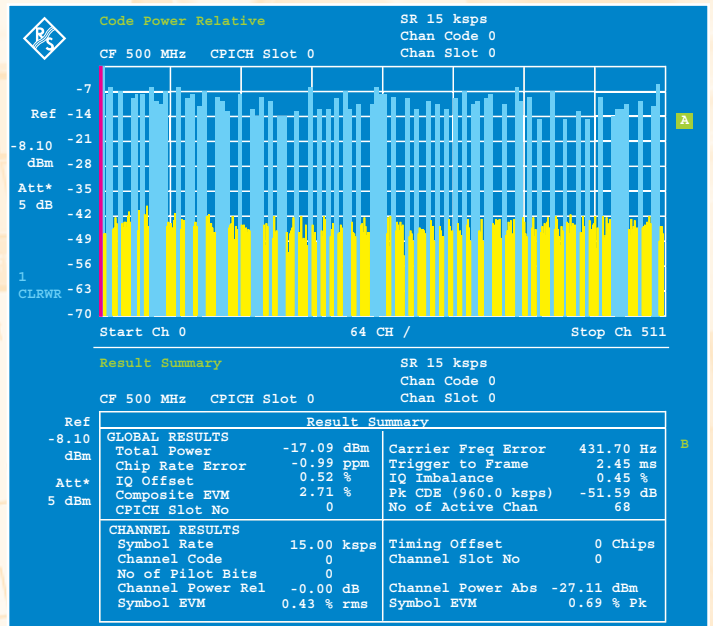

FIG 3 3GPP signal, test model 1 with 64 channels: ACLR typically 54 dBc.

FIG 4 WCDMA signal, test model 1 with 64 channels: EVM: 2.7%; peak CDE: -51.5 dB.



Condensed data of the R&S® SM 300

- Frequency range RF: 9 kHz to 3 GHz; AF: 20 Hz to 80 kHz
- Frequency resolution 0.1 Hz
- Modulation modes AM, FM, φM, pulse, I/Q
- Level resolution 0.1 dB
- Level uncertainty <1 dB (for levels >-120 dBm)
- Level range -127 dBm to 13 dBm
- Setting times for frequency and level <10 ms
- Single-sideband (SSB) phase noise <-95 dBc(1 Hz) at f = 1 GHz, Δf = 20 kHz
- Internal modulation generator 20 Hz to 80 kHz



FIG 5 R&S Smart Instruments™ – A strong trio (left to right): the Spectrum Analyzer R&S® FS300, the Vector Signal Generator R&S® SM300, and the new Function/Arbitrary Waveform Generator R&S® AM300, which will soon be available.

► An important amplifier test in digital mobile radio applications is adjacent-channel power measurement based on the WCDMA (3GPP) standard. The R&S® SM300's dynamic range allows measurements on WCDMA mobiles, for which the standard specifies an adjacent channel leakage ratio (ACLR) of 35 dBc in the first adjacent channel. Manufacturers of mobile phones stipulate a value of typically 5 dB to 8 dB better than the standard in order to be reliably below the permissible limit. Taking into account the required signal-to-noise ratio of 10 dB, a dynamic range of 50 dB to 53 dB is obtained for the signal generator. The R&S® SM300 has an ACLR typically as high as 54 dBc (FIG 3).

Another important parameter to be measured on digitally modulated signals is the error vector magnitude (EVM), which likewise provides information about the transmission characteristics of the components used. The EVM expresses the deviation of the signal at the DUT output from the ideal signal and is thus a measure of the transmission quality. The crucial requirement for the signal generator with respect to this measurement is a low inherent error value to avoid distortion of results. For a WCDMA signal in line with the 3GPP standard, for example, the R&S® SM300 has an inherent EVM of less than 3% and is thus far below the permissible limit value (FIG 4).

In the case of GSM signals, the phase error is measured instead of the EVM. The GSM Specification 05.05 defines a limit value of 5° for the root-mean-square (rms) phase error. With a static phase error of typically 1.1°, the R&S® SM300 here too remains far below the permissible limit.

## Remote control via the USB

The R&S® SM300 can be remotely controlled from a PC via its USB interface implemented as standard. Software drivers are available for LabView and LabWindows/CVI; a dynamic link library (DLL) exists for all common development languages (Visual Basic, C++, Delphi, MATLAB, etc). The command structure used for the drivers is the same as in other Rohde & Schwarz signal generators and is designed for fast programming of the instrument. The software drivers can be downloaded from the Internet and are continuously updated for all Rohde & Schwarz instruments.

In addition to the software drivers, a free program is available for the R&S® SM300 that allows convenient remote control of the instrument from a PC without any programming expertise required on the part of the user. This application supports all generator commands; in addition, all instrument settings can be stored on hard disk.

The program can be started separately for each instrument of the Family 300 connected to the PC, which means that several different units of this family can be controlled simultaneously. Measurement tasks involving several units can thus be controlled from a single PC. Commercial USB cables are used for connection to the PC, so that no extra hardware such as expensive IEC/IEEE bus cards is needed.

## Summary

The R&S® SM300 is available from € 6500<sup>1)</sup>. In addition to a frequency range from 20 Hz to 3 GHz, it features a wide variety of modulation capabilities and setting options not available at this price from any other supplier. Unprecedented in this price category is the standard I/Q modulator, which opens up a wide range of applications including digital mobile radio measurements.

And, of course, the R&S® SM300 offers the well-known advantages of the Family 300 platform concept: wide range of functions, compact design, 5.4" colour display, effective RF shielding, universal carrying handle and a user-friendly operating concept – all of which makes it easier for the user to solve complex measurement tasks.

Robert Oberreis

More information and data sheet at  
[www.rohde-schwarz.com](http://www.rohde-schwarz.com)  
(search term: SM300)



### REFERENCES

- [\*] Spectrum Analyzer R&S® FS300 – Favourably priced and universal for laboratory, service and production. News from Rohde & Schwarz (2003) No. 177, pp 20–23

1) Recommended sales price within the EU.



44032

FIG 1 WLAN measurements on the Signal Analyzer R&amp;S® FSQ.

Signal Analyzer R&amp;S® FSQ/Spectrum Analyzer R&amp;S® FSP

## WLAN measurements with analyzers from Rohde & Schwarz

**New options expand the scope of applications of the R&S® FSQ [1] and R&S® FSP [2] analyzers by spectrum and modulation measurements on OFDM signals in accordance with the WLAN standards IEEE 802.11a/g. Numerous measurements as specified by the standards are thus available at a keystroke.**

### WLAN requires efficient analyzers

Compared to single-carrier modulation methods, the multicarrier method that is used with the wireless LAN standards IEEE 802.11a and IEEE 802.11g places new requirements on transmitters and receivers, and thus also on T&M technology. For example, the high crest factor of these signals calls for an amplifier design that is matched to the signal. Then there is the additional challenge that a complete 802.11g module requires the implementation of both a single-carrier and a multicarrier modulation method in a single instrument.

Rohde & Schwarz therefore offers WLAN options tailored to development and production that complement the high-end

Signal Analyzer R&S® FSQ (FIG 1) and the favourably priced Spectrum Analyzer R&S® FSP.

### Standards 802.11a and g

WLAN signals in accordance with the standard 802.11a are defined for gross transmission rates from 6 Mbit/s to 54 Mbit/s; transmission is via OFDM. A total of 52 single carriers spaced at 312.5 kHz are used; four carriers in their function as pilots are BPSK-modulated. Each of the remaining 48 carriers is either BPSK-, QPSK-, 16QAM- or 64QAM-modulated. The signal itself occupies approx. 16 MHz, the channel bandwidth has been specified at 20 MHz, and the channel center frequency is an integer multiple of 5 MHz. With 802.11a, the signal is transmitted at 5.6 GHz, with 802.11g OFDM at 2.4 GHz.



The standard 802.11a specifies a series of transmitter measurements. However, in development and production, requirements go beyond these measurements. Both Rohde & Schwarz analyzers therefore support a multitude of other measurements – in addition to those defined in the standard. Moreover, both instruments also provide all the functions of a spectrum analyzer.

### R&S®FSQ high-end tester

The R&S®FSQ with WLAN option is a high-end tester for development and production. The 802.11a signal occupies a bandwidth of nearly 20 MHz which cannot be processed by conventional RF spectrum analyzers. This is where the R&S®FSQ with an RF bandwidth of up to 28 MHz that can be vector-analyzed shows off its advantages. Signal analyses in the 5 GHz band (802.11a), in the 2.4 GHz band (802.11g, OFDM), on any IF between 10 MHz and 3.6/8/26.5 GHz (FIGS 2 and 3) and in the baseband (with optional analog baseband inputs) are thus feasible.

### WLAN options for the R&S®FSQ and the R&S®FSP

- ◆ Complex WLAN OFDM measurements at a keystroke
- ◆ For laboratory and production
- ◆ Measurements at RF, IF or in the baseband
- ◆ EVM and spectral measurements
- ◆ Fully configurable in only two windows
- ◆ Remote-controllable and fast
- ◆ Spectrum and signal analyzer in a single instrument

Extremely low inherent and phase noise, unrivalled low residual error vector magnitude (EVM), high dynamic range as well as outstanding accuracy make the R&S®FSQ the ideal high-end tester for the development of baseband ICs, amplifiers and modules where tolerances and limit values often have to be narrower than specified in the standard.

### Convenient to operate

Two simple tables (FIG 4) provide an overview of all settings of the WLAN option, making it possible to change them at a keystroke. Once the application has been started, only the frequency/channel number needs to be entered before the measurement can start. The analyzer follows level changes by means of the optional auto-level function which makes manual entries superfluous.

It is therefore very easy to perform single measurements, measurements with a definable number of bursts, coherent measurements within a settable period of time or continuous measurements. The results are output in a table (incl. limit values) or as a graphical display (incl. limit value lines and pass/fail information) in one or two windows simultaneously (FIG 5).

The WLAN option can be remote-controlled via the IEC/IEEE bus and LAN, which is a prerequisite for use in production.

FIG 2 Standard-conformant spectrum measurement with mask and pass/fail information.

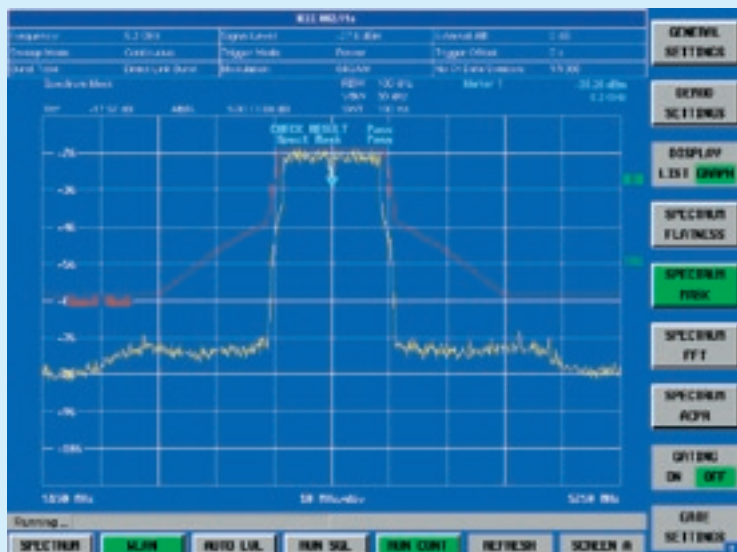
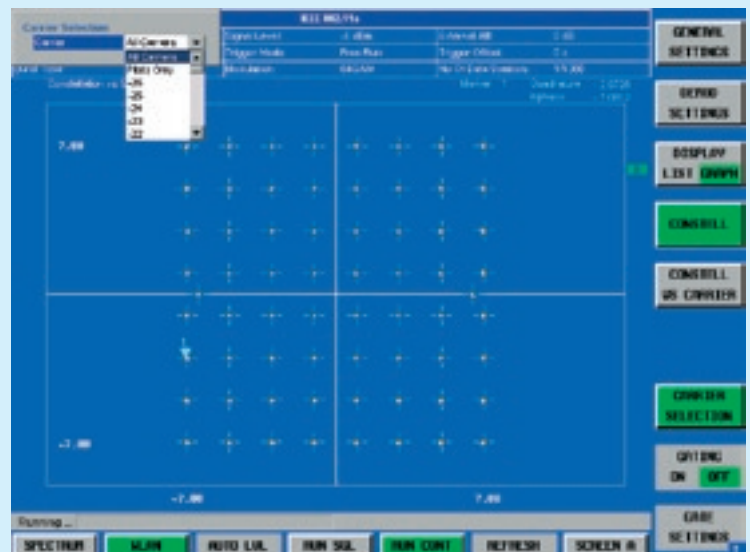

FIG 3 Constellation diagram of all or (selectable) individual carriers.



### General Settings

**Signal Characteristics**

- Standard: IEEE 802.11a
- Frequency: 5.2 GHz
- Channel No: 40
- Auto Level:
- Ext AE: 0 dB
- Signal Level (RF): -6.8 dBm
- Signal Level (Baseband): 1 V

**Data Capture Settings**

- Capture Time: 1 ms
- Overall Burst Count:
- No of Bursts to Analyze: 20

**Trigger Settings**

- Trigger Mode: Power
- Trigger Offset: 0 s
- Power Level (RF): -33 dBm
- Power Level (Baseband): --
- Auto Power Trigger Lvl:

**IQ Settings**

- Swap IQ:

**Input Settings**

- Baseband Input:
- IQ Input: 50 Ohm
- Balanced:
- Low Pass:
- Dither:

FIG 4 The two tables permit a quick overview of the selected settings plus quick access to the setting parameters.

### Demod Settings

**Burst To Analyze**

- Use Signal Field Content:
- Burst Type: Direct Link Burst
- Auto Demodulation:
- PSDU Mod to Analyze: 64QAM
- Equal Burst Length:
- Min No of Data Syms: 1
- Max No of Data Syms: 1366
- CH Est in Preamb & Payl:

**Tracking**

- Phase:
- Timing:
- Level:

Result Summary						
No. of Bursts	20 of 20					
	Min	Mean	Limit	Max	Limit	Unit
EVM All Carriers	0.52	0.58	5.52	0.65	5.52	%
	-45.62	-44.65	-25.00	-43.80	-25.00	dB
EVM Data Carriers	0.52	0.58	5.52	0.65	5.62	%
	-45.71	-44.73	-25.00	-43.81	-25.00	dB
EVM Pilot Carriers	0.58	0.62	39.51	0.69	39.91	%
	-45.17	-44.17	-15.00	-43.17	-15.00	dB
IQ Offset	-53.64	-53.00	-15.00	-52.63	-15.00	dB
Gain Imbalance	0.14	0.18	0.21			%
	0.01	0.02	0.02			dB
Quadrature Offset	-0.07	-0.05	-0.03			°
Center Frequency Error	-140.22 Hz	-140.22 Hz	+104.00 Hz	-140.22 Hz	+104.00 Hz	Hz
Symbol Clock Error	-0.24	0.11	± 2%	0.79	± 2%	ppm
Burst Power	-1.14	-1.09	-1.05	-1.05	-1.05	dBm
Crest Factor	0.73	0.51	10.25			dB

FIG 5 Display of the main parameters at a glance: The measurement covering 20 bursts shows an EVM of -45.62 dB for the "best" burst (min) and -43.8 dB for the worst burst (max) as well as an average EVM of 44.65 dB for all bursts. The red figures indicate that the measured frequency error value exceeds the limit value specified by the standard.

FIG 6 Burst configuration.

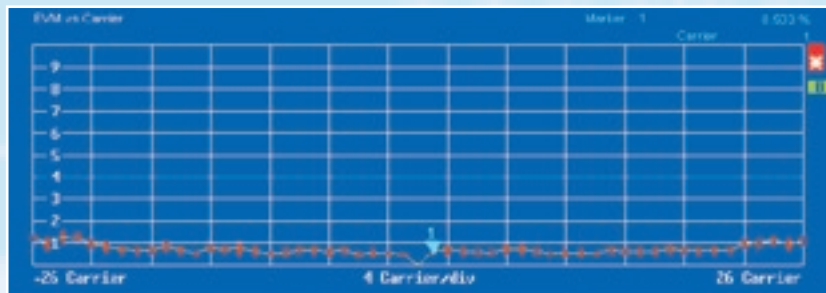
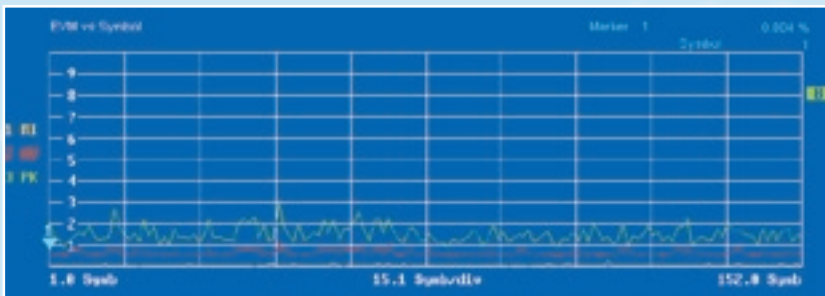
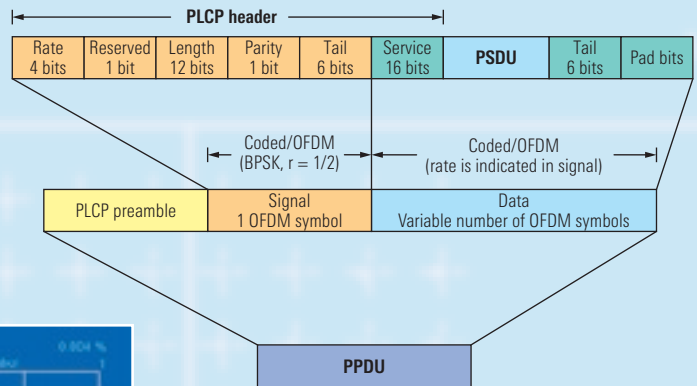

FIG 7 EVM versus symbols (top) or versus carriers (bottom).

### ► Useful in development

Signals in accordance with WLAN 802.11a/g may contain bursts that vary in modulation modes and lengths. The developer is often faced with the task of filtering the bursts according to a specific modulation mode and specific length from this mixture, demodulating them and comparing them to limit values.

The WLAN option also frees the developer from having to perform this task. Both the modulation mode to be analyzed and the burst length (number of payload symbols) can be set in such a way that only those bursts are analyzed that correspond to these criteria. Together with the settable number of bursts to be measured, it is for example possible to automatically detect and measure 64QAM-modulated bursts and bursts with a length of 67 payload symbols in such a mixture.

The duration of the intervals between the transmitted bursts can vary as well. If long intervals are expected, measurement speed can be further augmented by selecting an appropriate trigger (free run, external or power trigger) and a signal-specific data-recording time. The trigger threshold is selected either manually or automatically.

The evaluation of the signal field – an information field in each burst in which, for example, the modulation mode and number of payload symbols are coded (FIG 6) – permits automatic modulation detection and a test to check whether the content of the signal field is correct. In the bit stream display, the transmitted raw bits can be checked for each burst and carrier.

Various in-depth analysis and evaluation capabilities for the development and verification phase are available, e.g. EVM versus all carriers or versus symbols (FIG 7).

### R&S®FSP – economical for production

When WLAN components are produced, reduced and very simple measurements are usually performed to maximize throughput. With its fast and highly accurate power and spectrum measurements, the R&S®FSP is the ideal spectrum analyzer for this purpose; complemented with the R&S®FSP-K90 option, it is also able to measure the modulation parameters of the WLAN signal on a reduced number of OFDM carriers. In accordance with a patent-pending method, it uses only the 28 inner carriers for modulation analysis which are completely sufficient for adjusting the EVM or the I/Q offset, for example.

### Summary

Thus, the R&S®FSQ and the R&S®FSQ-K90 cover all requirements in development while the R&S®FSP and the R&S®FSP-K90 provide an economical solution for production.

In addition to spectrum analysis, the analyzers of course handle the full range of modern communication methods. In times of rapid change, measurement applications for GSM/EDGE, WCDMA, HSDPA, cdma2000 and TD-SCDMA ensure a flexible response to shifting market priorities. The Signal Analyzer R&S®FSQ is also ideal for handling bandwidth requirements exceeding 30 MHz.

The R&S®FSQ-K70 vector signal analysis option expands the R&S®FSQ by universal demodulation and analysis functions for digitally modulated signals up to a symbol rate of 25 Msymb/s.

Johannes Steffens

More information and data sheets at  
[www.rohde-schwarz.com](http://www.rohde-schwarz.com)  
(search term: FSQ and FSP)



R&S®FSQ-K90  
data sheet



R&S®FSQ brochure/  
specifications



R&S®FSP  
brochure



R&S®FSP  
specifications

### REFERENCES

- [1] Signal Analyzers R&S®FSQ – Bandwidth and dynamic range for future systems and technologies. News from Rohde & Schwarz (2002) No. 174, pp 17–21
- [2] Spectrum Analyzer R&S®FSP – Medium class aspiring to high end. News from Rohde & Schwarz (1999) No. 166, pp 4–7 – IEEE standards 802.11a/b/g.



Photo: Advantest

**FIG 1** The new Spectrum Analyzer R3681 from Advantest with the WLAN modulation analysis module.

### Spectrum Analyzer R3681 from Advantest

## Broadband modulation analysis for wireless LAN

**Flexible and future-oriented measurement solutions are vital for the follow-on development of WLAN technology.**

**The new Spectrum Analyzer R3681**

**from Advantest (FIG 1) with WLAN**

**modulation analysis places special**

**emphasis on this aspect.**

The increasing demand for broadband data communication – not only at home and at work, but also while on the road, for example during business trips – has considerably advanced wireless LAN technology. The need for higher data rates as well as regional differences have resulted in different versions of this standard. This is why the follow-on development of WLAN technology requires flexible and future-oriented measurement solutions. The new Spectrum Analyzer R3681 from Advantest with WLAN modulation analysis gives special consideration to this aspect.

### Modular design

The future-oriented high-end spectrum analyzer with modular design can be upgraded by means of different modules, for example one for broadband modulation analysis which, coupled with appropriate software options, covers a wide range of modulation standards. The first option available is WLAN. Additional standards such as WCDMA/3GPP will be added over time. Other modules include an arbitrary waveform generator and a signal generator. ▶

# Signal analysis – comprehensive, flexible and straightforward

In addition to HiperLAN/2 and HiSWANa, the option for WLAN signals also analyzes the standards 802.11a/b/g. Analysis can be carried out either via the RF input or the I/Q baseband inputs. An automatic analysis function makes complicated settings on the analyzer superfluous because it automatically recognizes the BPSK, QPSK, 16QAM and 64QAM modulation modes – and analyzes even signals with different modulation modes in each subcarrier. Moreover, it permits the analysis of signals that do not conform to standard, e.g. OFDM signals without preamble, which is of particular interest in development.

It's up to the user to decide which symbols of the signal are to be used for analysis. For example, a BPSK constellation diagram of the preamble or a 64QAM constellation diagram of the data signal based on any number of symbols anywhere in the data signal can be displayed. The analysis can, of course, also be performed for the entire signal.

A wide variety of measurement parameters make the R3681 an ideal tool in research and development. They far surpass the parameters specified in the standards and help developers to find the source of problems. For example, the *EVM versus Time* function displays the value of the error vector of each individual symbol; if the overall EVM value is too high, its exact cause can thus be determined.

The 12.1" touch screen displays up to four different subscreens simultaneously, which is particularly beneficial in modulation analysis. A novel zoom function in the spectrum mode permits vertical or horizontal zooming of signals by defining the zooming area by activating the touch screen. The main WLAN measure-

ment parameters are output in a table or in a number of sophisticated graphical displays (FIGS 2/3). This includes EVM values, magnitude and phase errors of all subcarriers individually as well as

versus time or symbols, the demodulated data, constellation diagrams and a spectrogram display, to name just a few analysis functions.

FIGS 2/3 The R3681 excels with versatile graphical analysis functions.

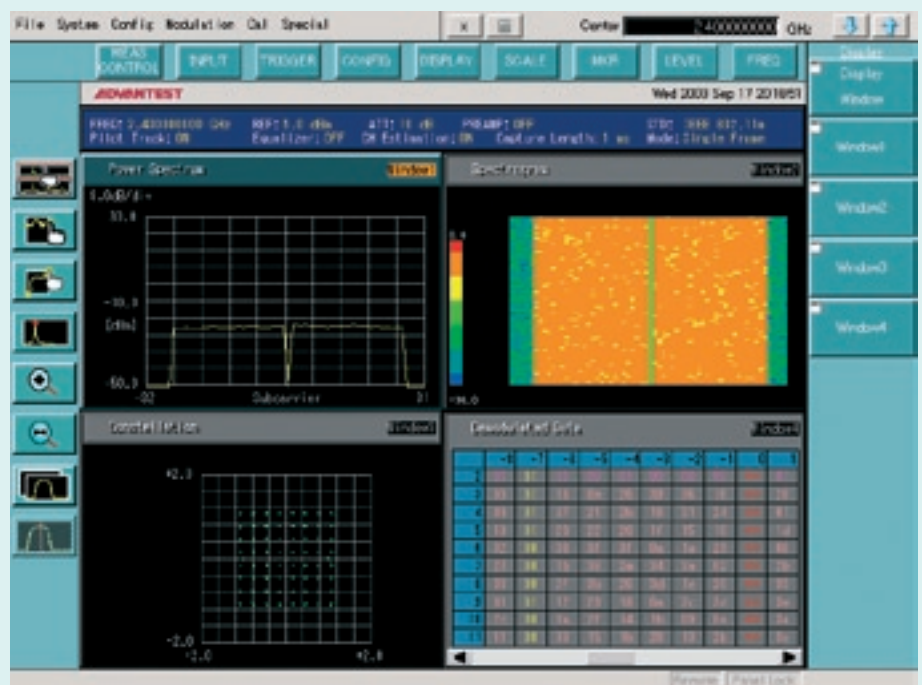
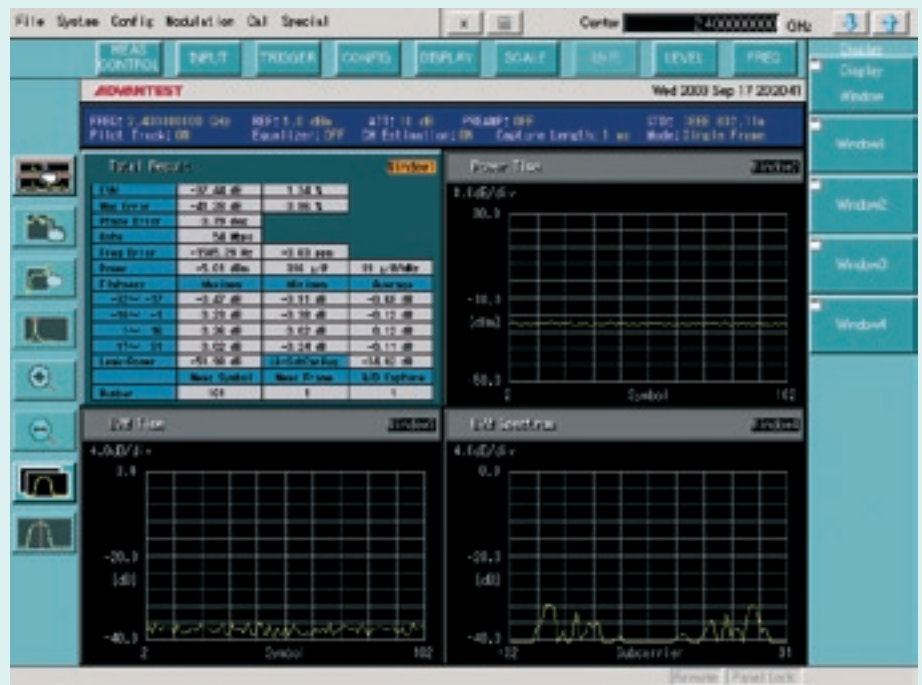

► **Simply top-class**

The R3681 is a first-rate spectrum analyzer covering the frequency range from 20 Hz to 32 GHz. With a noise floor of typically  $-158$  dBm at 1 GHz that can be reduced to  $-168$  dBm by using an internal preamplifier, a level uncertainty of only 0.2 dB and an S/N ratio of  $-122$  dBc(1 Hz) with 10 kHz spacing at 800 MHz, it satisfies the most rigorous requirements in research and development.

**Automatic software routines**

Optional automatic software routines perform transmitter measurements, e.g. the transmit spectrum mask or spurious measurement (transmission spurious), in accordance with the standards 802.11a/b/g and the specific requirements as defined by the FCC (USA) or TELEC (Japan) (FIG 4).

**Arbitrary waveform generator**

An optional AWG module generates diverse signals with a memory depth of 64 Msamples on each of the two channels. These 64 Msamples can be divided into  $4 \times 16$  Msamples and stored to four different memories and quickly switched. The four memories for the generation of BPSK, QPSK, 16QAM and 64QAM signals can be used simultaneously, for example. The AWG module offers a resolution of 14 bits and a sampling rate of 200 MHz.

Signal analysis can thus be carried out in the I/Q plane or, with an additional signal generator module, in the WLAN frequency range. It is also possible to analyze the bit error ratio (BER) by means of a built-in counter. In addition, external software permits the analysis of the packet error ratio (PER).

**Summary**

The combination of high-end spectrum analyzer, flexible and versatile WLAN modulation analysis, signal and arbitrary waveform generator modules and future expandability with regard to bandwidth and modulation standards make the R3681 a future-oriented investment. It has been designed for higher bandwidths than the currently implemented 25 MHz and will be expandable to a bandwidth of up to 140 MHz in the future. Thus, expansions of the WLAN standard necessitating higher bandwidths can subsequently be integrated into the analyzer.

Andreas Henkel

**FIG 4**  
Measurement of the transmit spectrum mask using automatic measurement software.

More information and data sheet at [www.rohde-schwarz.com](http://www.rohde-schwarz.com) (search term: R3681)

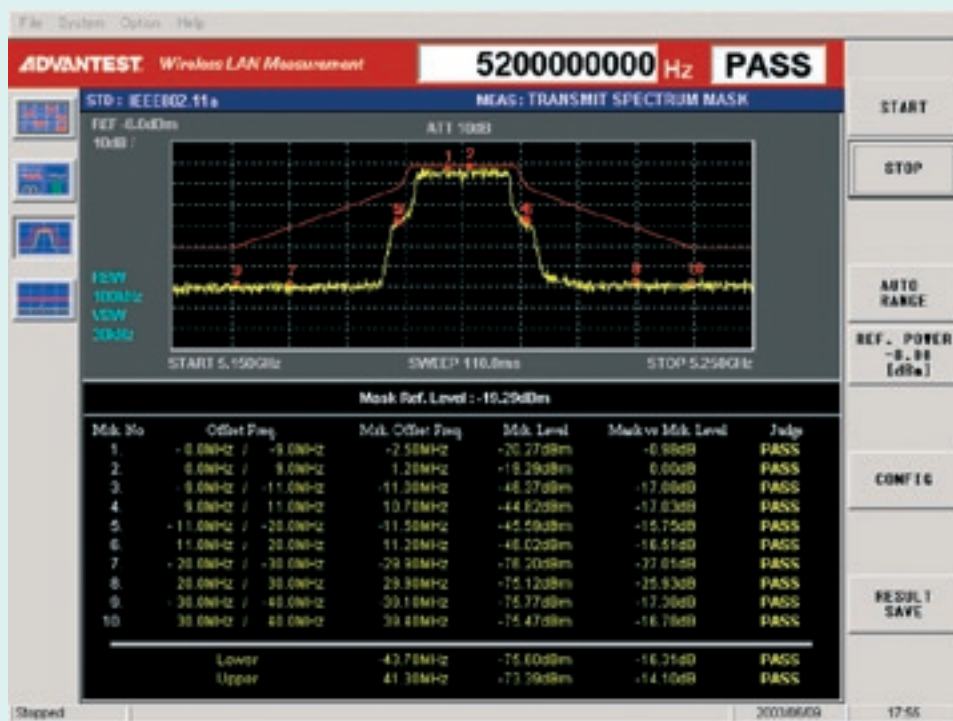

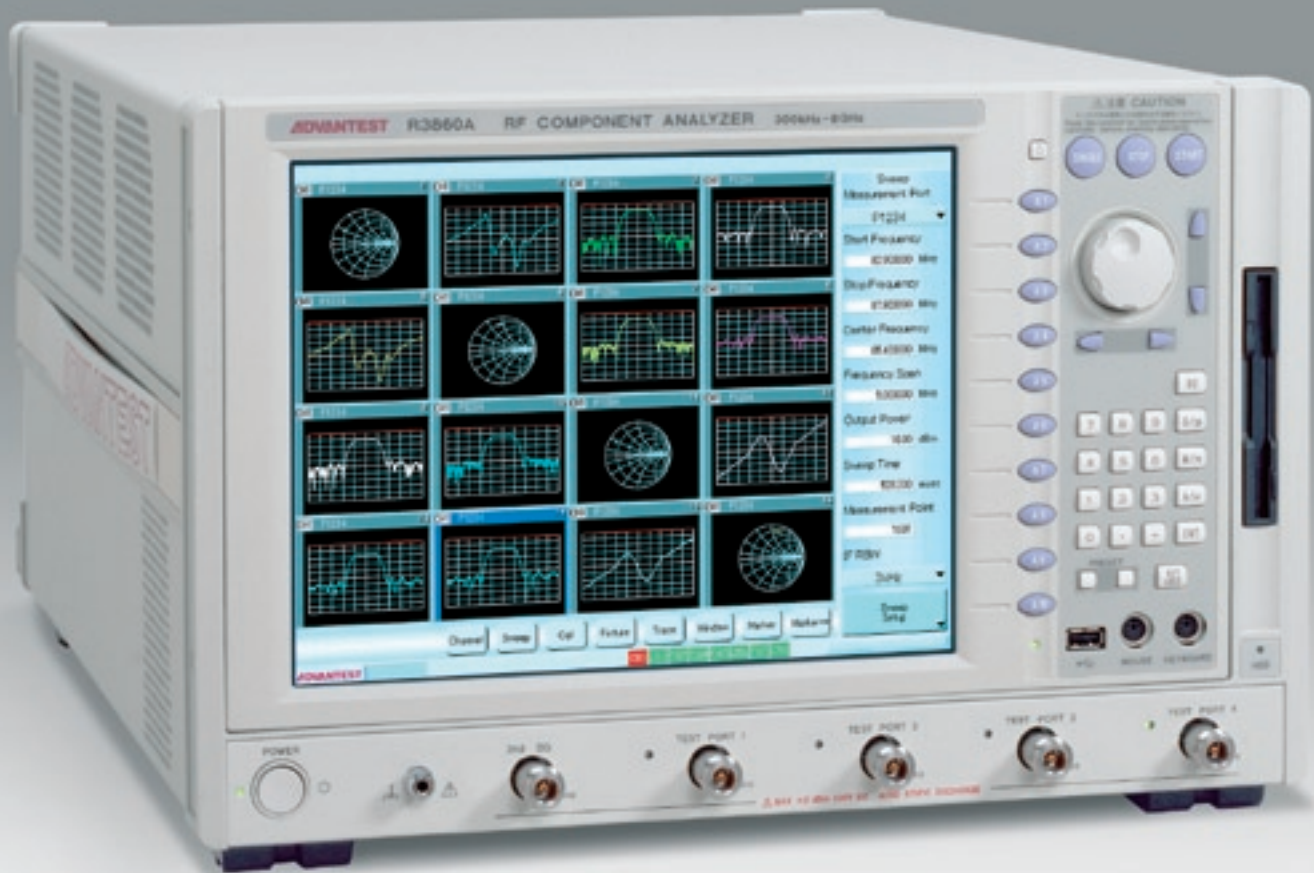

Photo: Advantest

FIG 1 The new R3860A allrounder from Advantest.

### RF Component Analyzer R3860A from Advantest

## Network and component analysis made easy

Advantest has launched its new R3860A network and component analyzer (FIG 1), an allrounder that satisfies the most diverse requirements.

### Committed to new trends

New trends in development such as balanced components are gaining in importance. Especially in mobile radio, they are favoured to an increasing extent. Because of the high innovation rate in mobile phones, more and more individual components are integrated into modules which can then include filter, mixer and amplifier – also in combined bal-

anced and unbalanced technology. At the same time, new developments such as wireless LAN require measurements in frequency ranges beyond 8 GHz.

This results in a completely new requirements profile for T&M equipment. By launching its new R3860A network and components analyzer, Advantest has put an instrument on the market that satisfies all these diverse requirements. ▶

## ► Multitalented

The R3860A is the first network analyzer on the market that combines in a single instrument measurements on passive components, e.g. filters, and measurements on mixers, balanced components and complex modules including their voltage supply. An internal signal generator allows the measurement of magnitude, phase and group delay of mixers.

The two models of the R3860A cover a frequency range of 300 kHz to 8 GHz and 300 kHz to 20 GHz.

## The fastest on the market

All this at unprecedented speed: With 5  $\mu$ s/test point, the R3860A proves to be the fastest network analyzer on the market. It is therefore ideal for production applications that require high throughput; but also in development, high measurement speed is ideal for complex measurement sequences.

## Touch screen and more

The analyzer provides a Windows® user interface and can be operated via the 12.1" SVGA TFT screen (touch screen) or

by means of a mouse and keyboard. In up to 16 individual screens, the different S-parameters can be combined in any display. The measurement results can be stored as graphical displays for documentation purposes and as measured values in different formats, e.g. Touchstone.

## Balanced measurements

To analyze balanced components, a series of simulation steps in the analyzer as well as the measurement of additional S-parameters are necessary. This in turn requires impedance conversion,

FIG 2 Balanced measurements made easy.

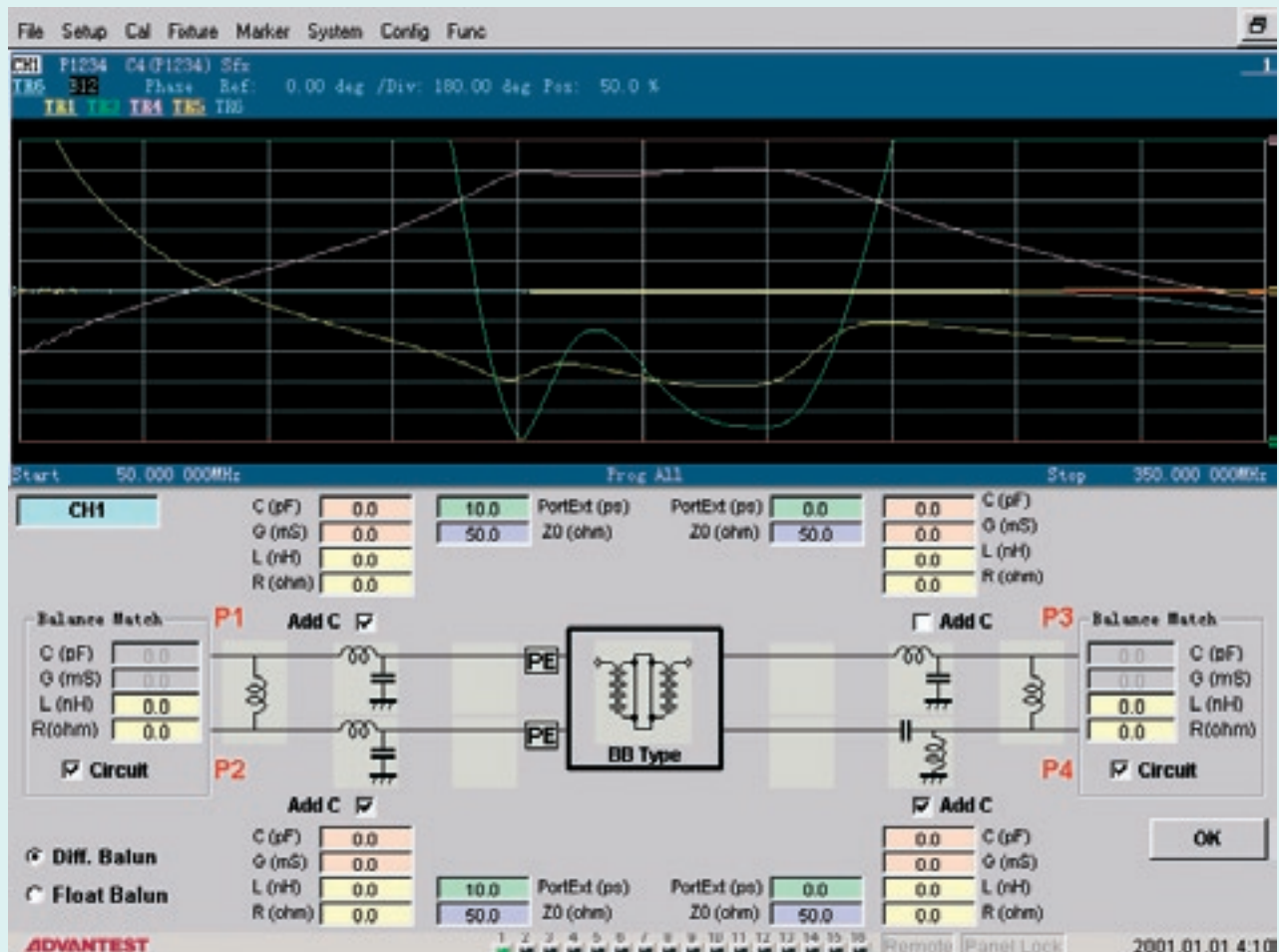



## The main aspects in brief

- ◆ Two models:  
300 kHz to 8 GHz and  
300 kHz to 20 GHz
- ◆ Two-, three- and four-port versions
- ◆ 5  $\mu$ s/point measurement speed
- ◆ 125 dB dynamic range (typ.)
- ◆ +13 dBm maximum output power
- ◆ 16 measurement channels
- ◆ Balanced measurements
- ◆ Mixer measurements with integrated signal source
- ◆ TDR measurement function

the simulation of baluns and adding or subtracting matching circuits. The measurement of differential S-parameters, referred to as mixed-mode analysis, is used to characterize the module with regard to unbalanced signal components. For example, it is important that a balanced filter is immune to electromagnetic interference which can be emitted in the mobile phone by the close-by antenna. Moreover, the degree of balance measurement according to magnitude and phase is used to characterize the quality of a balanced DUT.

All this can be easily set in the analyzer with graphical support so that handling is straightforward and user-friendly (FIG 2).

## Measurement sequences

The characterization of complex modules, for example antenna switching modules for mobile phones, necessitates a host of single measurements. By means of automation software, any number of single measurements can be combined to form

a sequence. For production applications, all necessary measurements on a component can thus be performed as a measurement sequence, compared to defined limit values and evaluated by means of pass/fail statements.

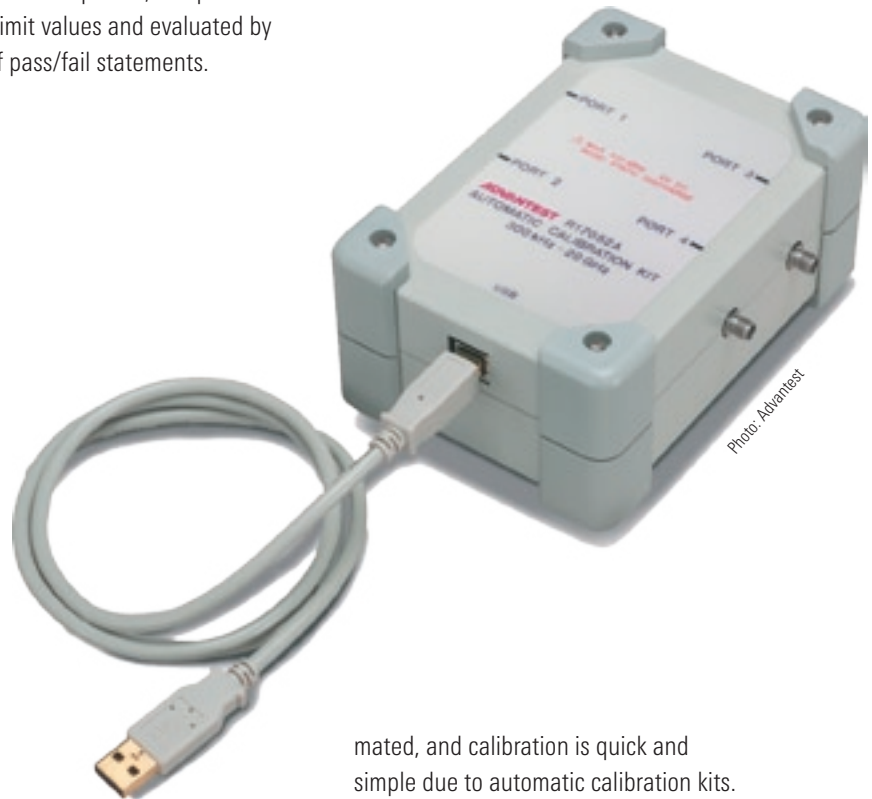

**FIG3**  
Fully automatic four-port calibration kit for the 300 kHz to 20 GHz frequency range.

## Automatic calibration kits

Automatic two-port and four-port calibration kits with 3.5 mm or N connectors save time and ensure correct calibration due to built-in verification routines. In addition to the 8 GHz version, Advantest is the first company to develop a fully automatic calibration kit for the 300 kHz to 20 GHz frequency range which is also available as a two-port and four-port version (FIG 3).

## Summary

The R3860A allrounder measures modules and components of all kinds. Since it is the fastest analyzer on the market, it is ideally suited for development and production; what's more, it can be auto-

mated, and calibration is quick and simple due to automatic calibration kits. Its modular design satisfies future measurement requirements just as well, and in times of constantly decreasing innovation cycles, this flexibility makes it a future-oriented measuring instrument.

Andreas Henkel

More information and data sheet at  
[www.rohde-schwarz.com](http://www.rohde-schwarz.com)  
(search term: R3860A)





It's been a year since Rohde & Schwarz introduced the new R&S® NRP [\*

power meter family for fast and accurate measurements on the complex RF signals of modern communication technology. Its dynamic range of 90 dB for modulated signals, high measurement accuracy as well as its future-oriented instrument concept where each sensor is a T&M instrument that can be remote-controlled via USB (FIG 1) were outstanding. Since then, a lot has happened ...

FIG 1 The R&S® NRP power meter family features a broad scope of different sensors.

Power Meter R&S® NRP

## Evolution in motion – new functions and sensors

Now even better

The extremely positive market response was one of the decisive factors for continuously enhancing this family. As a result, firmware revision 3.0 provides the following new functions for the R&S® NRP base unit: time-domain display with possible gate measurements, fast configuration for standard signals, remote control via USB interface,

Ethernet LAN operation (with option R&S® NRP-B4) and the capability to test connected sensors at a keystroke. Moreover, the sensor portfolio has been expanded, so that multiple-path diode sensors that are staggered according to power (up to 30 W) are now available as well as a thermal sensor up to 18 GHz. Standard drivers (VXI Plug&Play, Lab-View, HP VEE) are provided for the base unit and all sensors.

## Time-domain display, measurement in time windows

Due to the complex signal shapes of today's communications standards, displaying the power envelope has become indispensable for visualizing signal details or for defining time windows (gates) for important power parameters (FIG 2). Operating this new functionality, which is available for all sensors of the R&S®NRP-Z11 and -Z2x type, on the R&S®NRP base unit is child's play: Select the Scope mode and graphical result display, set the trigger and horizontally and vertically define the required size of the screen window. In the time-domain display, as in normal operation, the wide dynamic range of the sensors is impressive. It allows measurements down to -50 dBm at a video bandwidth of 100 kHz.

For measurements in time windows, up to four different gates can be defined on the R&S®NRP in the Scope mode; the average power (AVG), the displayed peak value (PK) and the PK/AVG ratio can be numerically displayed for each gate. The power meters' capability of producing and displaying the ratio of the gated measurement results of two different sensors is unprecedented. It is thus, for example, quite simple to measure the gain or gain compression of a power amplifier in specific sections of a test signal and display it together with the envelope (FIG 3).

## Signal-specific configuration

Some measurement functions such as the display of the envelope power as a function of time and power measurements in gates or entire frames require a multitude of signal-specific settings. This can be quite tedious and presupposes some knowledge about the measurement signal. For this reason, the entire configuration of a signal can now be

loaded at a keystroke on the R&S®NRP base unit by selecting and activating the signal type from a list of common communications standards (FIG 4). Since the user can still change all parameters after the configuration, the optimum setting can be found in no time, and setting errors are minimized.

## New sensors

Based on the Power Sensor R&S®NRP-Z21 (10 MHz to 18 GHz, -67 dBm to +23 dBm), there are now also new versions for directly measuring the output signal of mobile and base stations, amplifiers and other powerful sources, specifically in the following power classes

- ◆ 2 W R&S®NRP-Z22
- ◆ 15 W -Z23
- ◆ 30 W -Z24

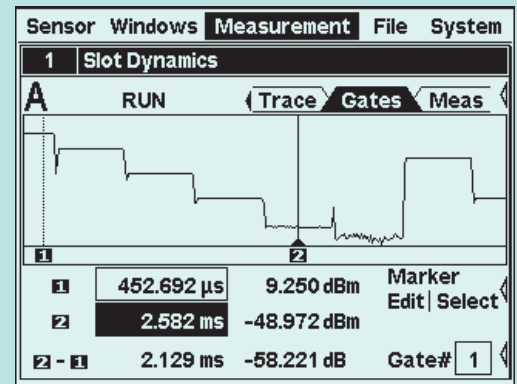

FIG 2

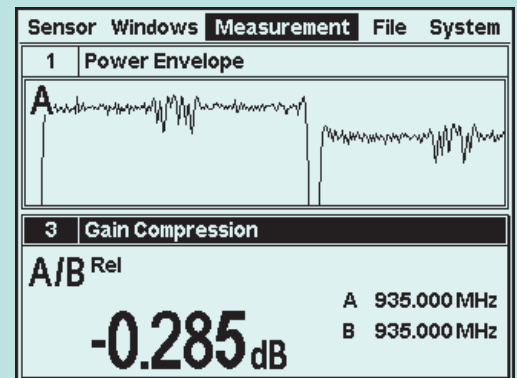

FIG 3

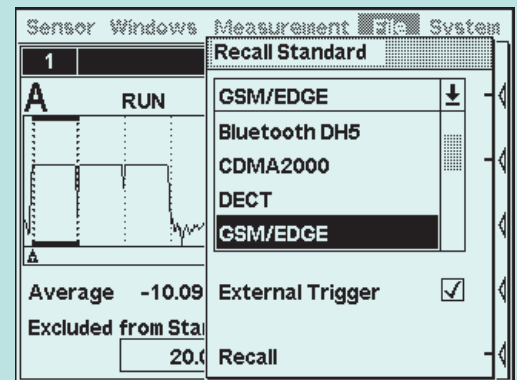

FIG 4

FIG 2 Scope mode on the R&S®NRP: Display of a GSM/EDGE frame with markers and measured values.

FIG 3 Scope mode on the R&S®NRP: Simultaneous display of a section of the power envelope together with the measured value for the compression of a power amplifier in a timeslot, measured by two R&S®NRP-Z11 sensors.

FIG 4 Configuration at a keystroke: The R&S®NRP base unit knows almost all common communications standards.

FIG 5 The differences between the sensor and the R&S®NRP-B1 power reference as determined by means of the sensor test can be output, if required.

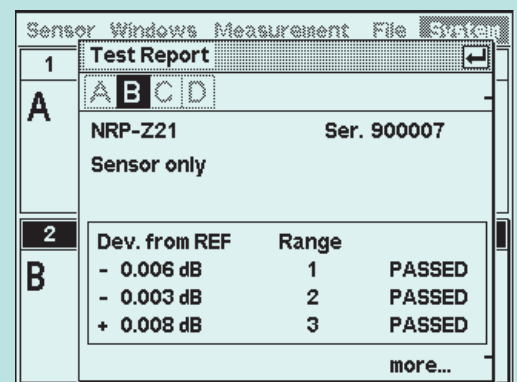

FIG 5

- ▶ The rugged attenuators – which have been successfully used by Rohde & Schwarz for well over ten years now – ensure reliable measurement results. Needless to say, effective thermal shielding in the 15 W and 30 W power classes as well as a low shape factor make handling as easy as with a standard sensor.

The fact that thermal sensors can still hold their ground against diode sensors – despite their lower dynamic range and lower measurement speed – is due less to nostalgia than several substantial advantages. With thermal sensors, the signal shape has absolutely no influence on the measurement result, and numerous characteristics such as linearity, frequency response and matching are completely temperature-independent. Moreover, the thermal sensors from Rohde & Schwarz feature excellent linearity due to customized correction of each sensor, plus DC coupling of the test cell, allowing measurements at almost any low frequencies as well as referencing the measurement result to DC.

All these are substantial reasons to offer new thermal sensors also for the R&S® NRP power meter family, at first for the frequency range of DC to 18 GHz and a nominal power of 100 mW (R&S® NRP-Z51). For the most part, the new sensor corresponds to the well-known predecessor R&S® NRV-Z51 but offers still more advantages: standalone operation on PCs as well as higher reproducibility of the measurement results by using only one measurement range and omitting the influence of the base unit.

Even with careful handling, the input of the sensor may be fed a power level that is too high, causing damage or even destruction. For this reason, a quick and simple test can now be performed on the base unit. In this case, the measurement error of the sensor compared to the power reference (option

R&S® NRP-B1) is checked and, if necessary, a warning is output (FIG 5). The warning threshold is user-definable; the test covers all measurement ranges. In the case of sensors with attenuators, the latter can be included in the test.

### Remote control

The R&S® NRP base unit comes with an IEC/IEEE bus and a USB interface as standard. The USB connection was originally intended only for the firmware update, but has by now been expanded to a fully-fledged remote-control interface. A prerequisite was the introduction of a new equipment class (USBTMC) by the USB Implementers Forum at the beginning of this year. As with the IEC/IEEE bus, it allows the interconnection of different measuring instruments to one measurement system, with the virtual instrument software architecture (VISA) library acting as the software interface to the application program of the user. The USB remote control functionality can be subsequently added to each R&S® NRP base unit by means of firmware revision 3.0. Customers intending to operate the base unit in a local area network (LAN) are now provided with an Ethernet interface with the VXI 11 protocol layer (option R&S® NRP-B4).

Right from the start, each sensor of the R&S® NRP family could be operated even without a base unit – by using one of the USB Adapters R&S® NRP-Z3 or -Z4 directly via the USB interface of a PC. A DLL provided by Rohde & Schwarz acted as the software interface. Due to the outstanding customer feedback on this operating mode, the software interface was developed further and simplified: The sensor can now also be addressed via standard drivers (VXI Plug & Play, Lab-View, HP VEE). Simultaneous operation of several sensors on a PC is now possible without any restrictions.

### Evolution continues

Many Rohde & Schwarz customers have already earmarked the R&S® NRP family as their new power meter standard. The R&S® NRP family is continuously being developed with a view to functionality, new frequency bands and in particular the requirements of future communications standards. As Europe's largest T&M manufacturer, Rohde & Schwarz is committed to satisfying its customers.

Thomas Reichel

More information and data sheet at  
[www.rohde-schwarz.com](http://www.rohde-schwarz.com)  
 (search term: NRP)



#### REFERENCES

- [\*] Power Meter R&S® NRP – Evolution in power measurement – intelligent sensor technology. News from Rohde & Schwarz (2002) No. 174, pp 12–16

## Dual-Channel Analyzer / Power Supply R&amp;S® NGMO2

# R&S® Current Sniffer: tracking down energy guzzlers

By conveniently detecting weak spots, the R&S® Current Sniffer helps designers of devices for the communications and entertainment industry to maximize the operating times of these largely battery-operated mobiles by optimizing the hardware and software.

## Long operating times needed

The communications and entertainment industry is currently experiencing a veritable boom of new battery-operated devices. These mobiles feature functionalities and capabilities that far exceed those only large mains-operated fixed devices provided a few years ago. In mobile use, however, one thing is common to them all: Their energy is supplied by batteries or rechargeable batteries, which means that their operating time is limited. By conveniently detecting weak spots, the R&S® Current Sniffer helps designers to maximize the operating times of these devices by optimizing the hardware and software.

## Long-term analyses

The R&S® Current Sniffer consists of a Dual-Channel Analyzer/Power Supply R&S® NGMO2 (FIG 1) and the R&S® NGMO2-K10 operating software. The R&S® NGMO2 has two identical supply and measurement channels that are connected in series by means of the R&S® Current Sniffer. Thus, the high time resolution of its current/voltage transients recorder of 10  $\mu$ s can be used to integrate current consumption. Moreover, long-term measurements can be performed by continuously switching between channel A and channel B: While measurements are performed with channel A whose measured value

**FIG1**  
The R&S® NGMO2 features two identical channels and has a lot more to offer than a conventional laboratory power supply. It is the hardware basis of the R&S® Current Sniffer.

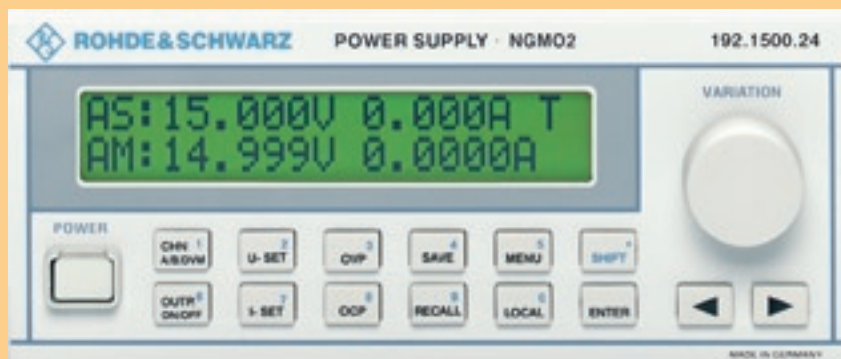

Dual-Channel Analyzer / Power Supply R&S® NGMO2

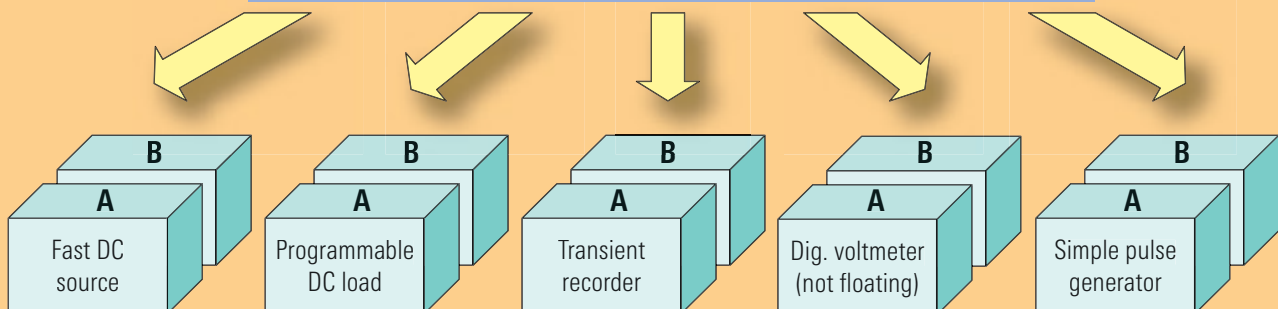

- ▶ memory is being filled, the measured value memory of channel B is cleared and the data transferred to the PC. This happens simultaneously, ensuring that every period of time is monitored and that the overall result for current integration is kept accurate. The advantage of this procedure is that the total energy consumed by the DUT during a specific period of time can be determined and, what's more, the possible causes of an increase in current drain can be traced because data is available in high time resolution.

To limit the amount of data involved in long-term measurements, it may be a good idea to use longer sampling intervals as well. Although this makes it more difficult to assign individual energy consumption events with regard to time, the individual measured values correspond to the actual current value of the period under observation because the R&S®NGMO2 internally always uses the highest possible sampling rate of 10 µs and always outputs the average of all samples in a sampling interval.

### Convenient operating software

The other crucial component of the R&S® Current Sniffer is the

R&S®NGMO2-K10 operating software (FIG 2). In addition to the long-term analysis of current consumption as detailed above, it is possible to carry out short-term analyses, battery tests as well as data postprocessing of the measurement sequences that are already recorded (FIG 3). In each case, device setups and information about the DUT can be documented, stored and ported for further use in other programs. The calculation of the battery capacity used, the remaining residual capacity, the energy used and the optional definition of different termination criteria all come in handy for long-term energy consumption analysis.

A complementary cumulative distribution function (CCDF) display in the post-processing submenu is very useful if the complex nature of the recorded measurement sequences makes it difficult to interpret them.

By example of a WCDMA mobile phone, FIG 4 illustrates how the R&S® Current Sniffer in the long-term current analysis mode provides suggestions on how to further increase the operating time of the phone. While the phone exhibits the expected high current drain at time ① because the telephone display has been activated, and current drain is significantly reduced at time ② because the

### Other fields of application of the R&S® Current Sniffer

- ◆ Development and servicing of
  - mobile phones
  - PDAs
  - portable game consoles
  - digital cameras and camcorders
  - portable CD and MP3 players
  - portable GPS receivers
  - portable measuring equipment
- ◆ Product comparisons by technical editors
- ◆ FPGA designer
- ◆ Ampere hour counter for chemical processes

display illumination has been switched off, relatively high current drain occurs at time ③ because the moving motif of a screen-saver has become active even though display illumination is switched off. Activating this saver reduces the overall operating time of the telephone. As expected, energy consumption increases again at time ④ while a call is attempted.

FIG 2 Measurement tasks that can be performed using the R&S®NGMO2-K10 operating software.

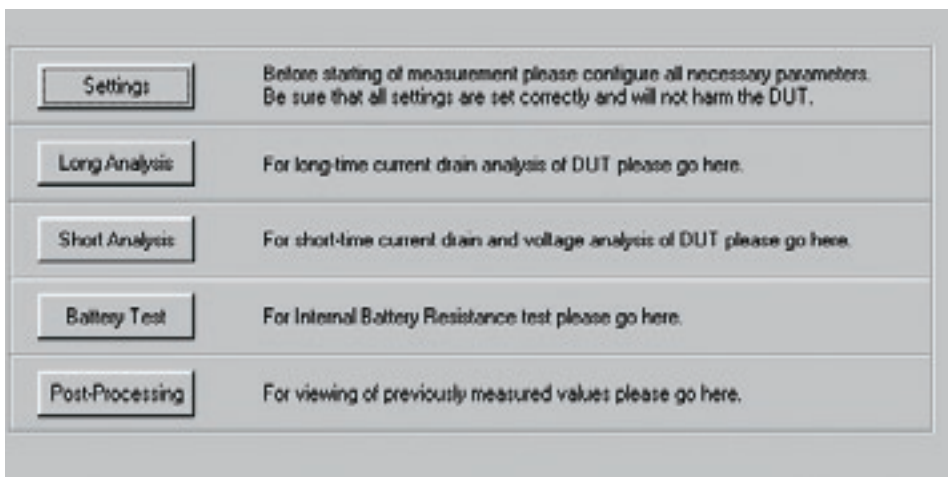

### Short-term analysis

The primary task of the short-term analysis (FIG 5) is a more thorough analysis of the periods of time that were determined to be critical in the long-term analysis. The short-term analysis is not restricted to pure current measurements; a short-term voltage analysis can also be selected where one of the two digital voltmeters integrated in the R&S®NGMO2 is used. Similar to an oscilloscope, voltage transients can be monitored during DUT switch-on, for example.

## Battery test

Batteries or rechargeable batteries are an integral part of mobile devices and thus also a possible cause for failure. Needless to say, service centers not only check the telephone electronics, but also the rechargeable battery. Again, the R&S® Current Sniffer provides first-class support: By determining the internal impedance of the rechargeable battery, its remaining expected lifetime can be deduced by means of a quick test. If the internal impedance of a rechargeable battery of the same technology and same series and which is in a charged state is considerably higher than specified in the reference data, its service life will soon expire.

By adding the optional R&S® NGMO2 switchbox including software expansion, the functionality of the R&S® Current Sniffer can be further enhanced. In addition to adapting true hardware handshaking via the “external trigger” and “measurement complete” signals, the switchbox also enables the switching of both power supply channels between series and parallel connections (with the appropriate guard circuit). The trigger generator integrated in the switchbox can thus generate GSM-typical pulse loads via the inhibit input of an R&S® NGMO2 channel.

Lutz Fischer

More information and datasheet at [www.rohde-schwarz.com](http://www.rohde-schwarz.com) (search term: NGMO2)

### REFERENCES

- [\*] Power Supply/Dual-Channel Analyzer R&S® NGMO2 – Fast dual power supply with analysis functions. News from Rohde & Schwarz (2001) No. 171, pp 30–32

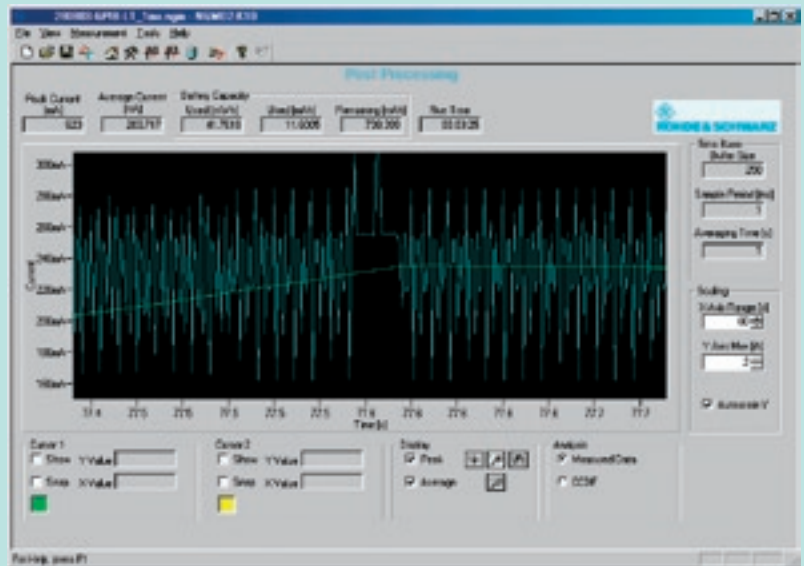

FIG 3 WCDMA mobile phone in standby after the display has been activated. By means of the zoom function, a subsequent detailed resolution of the periods of time under test is possible.

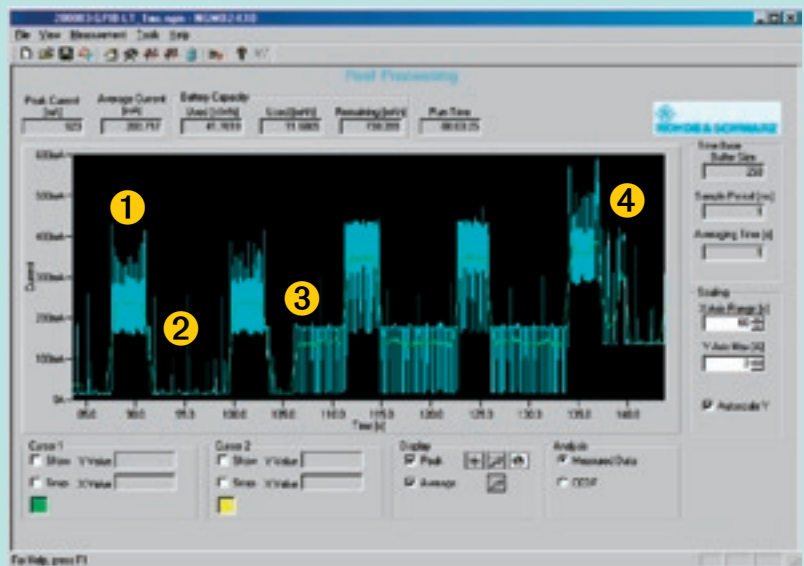

FIG 4 The “fingerprint” of a WCDMA mobile phone in the long-term current analysis mode of the R&S® Current Sniffer reveals possible energy guzzlers.



FIG 5 Short-term current analysis on an older GSM mobile phone.

## Portable System for EMF Measurements R&amp;S® TS-EMF

# How ambient conditions influence electromagnetic field measurements

**The R&S® TS-EMF [\*] from Rohde & Schwarz is a versatile system for measuring high-frequency electromagnetic compatibility in the environment. Even if receive conditions are difficult (e.g. multipath propagation due to reflections), EMF measurements must be able to reliably and reproducibly determine peak and average field-strength values. In this case, ambient conditions have a large impact. This article presents the latest findings on the influence of ambient conditions, based on measurements with the R&S® TS-EMF.**

Versatile configurability and specific measurement modes (long-term measurements, determination of peak and average values) make the R&S® TS-EMF system (FIG 1) ideally suited for measurements at a fixed location and fundamental measurements. The new measurement routines for measuring across several points in a room are a special advantage.

In cooperation with Prof Dr Wuschek from the University of Applied Sciences Deggendorf, Rohde & Schwarz performed EMF measurements and analyzed spatial field distribution and signal timing.

## Spatial level fluctuations

Shadowing and interference with reflected signals result in significant field-strength fluctuations at the reception site, especially in buildings. FIG 2 shows an example of field-strength distribution in a room alongside a straight line. If, in this case, measurements were carried out at only one point, measurement errors in the order of 20 dB could occur.

Magnitude and period of the fluctuation depend on the strength and distance of the reflection. In particular if there are



43.94/7

**FIG 1**

The R&S® TS-EMF measures electromagnetic fields in the environment. These measurements provide a basis for discussions about the effects of electromagnetic radiation.



many different overlapping reflections, behaviour becomes erratic and cannot be anticipated. It is therefore necessary to use specific measurement methods in order to reproducibly measure the maximum or average value even under these circumstances.

To do so, mainly the stirring method and the multipoint method have become established. With the stirring method, the antenna is shifted in all directions across a spatial volume and the maximum value of the field strength is recorded. With the multipoint method, measurements – from which the peak or average value is derived – are performed in defined spatial intervals. The multipoint to be used is still being discussed by experts; one possibility is specified in the European standard prEN 54 000 which is currently being created.

Outside of buildings, reflection conditions are simpler since it is usually the ground that causes the main reflection. Thus, a few measurement points of the multipoint method yield excellent results. FIG 3 shows a comparison between the multipoint method (three measurement points at different heights) and the stirring method, indicating a good match.

### Level fluctuations as a function of time

Level fluctuations as a function of time may be caused by changes in the transmit power (e.g. changing traffic volume in mobile radio) and/or influences by the current measurement environment (e.g. weather).

FIG 4 shows the result of measuring the timing of transmitters with constant power (e.g. organization channel BCCH with GSM). The same location was selected as for measuring the spatial level fluctuations (FIG 2). It turns out that the level is time-constant if the trans-

mit power and the weather conditions remain constant, despite significant spatial fluctuations. The reflection conditions are therefore of minor importance for long-term measurements which refer above all to changes in field-strength. Thus, fluctuations due to transmit power or weather conditions can be reliably determined by means of long-term measurements. FIG 5 shows an increase in the GSM network utilization, in which case voice channels that are only occasionally active are added to the signalling channels with constant power that are always present.

With short-term measurements, no information is available about the current system utilization. For this purpose, measurement methods are applied that extrapolate to the worst case, i.e. maximum utilization of a base station. This ensures that the measured value is independent of system utilization.

### Summary

If there are significant spatial level fluctuations, especially in buildings, suitable measurement methods (stirring method, multipoint method) ensure high measurement accuracy and reproducibility. Spatial fluctuations have no direct impact on the timing of signals. Long-term measurements with fixed, isotropic antennas are therefore ideally suited for the characterization of changes in the field strength due to different system utilization or weather influences.

Jürgen Kausche

More information and data sheet at [www.rohde-schwarz.com](http://www.rohde-schwarz.com) (search term: TS-EMF)

#### REFERENCES

- [\*] Portable System for EMF Measurements R&S® TS-EMF – Accurate measurements of electromagnetic fields caused by transmitter systems. News from Rohde & Schwarz (2003) No. 177, pp 29–31

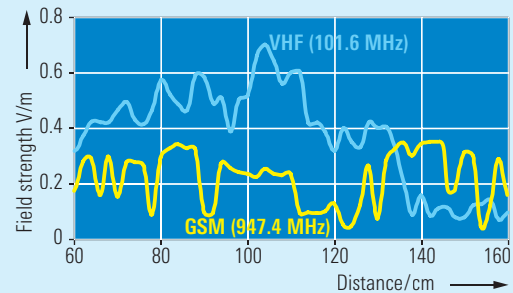

FIG 2 Field-strength distribution within a room.

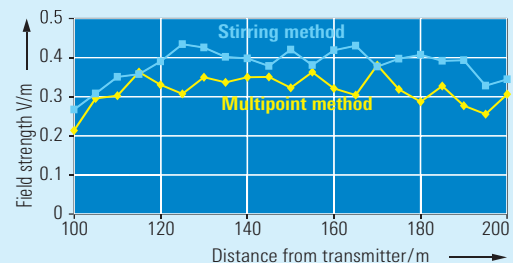

FIG 3 Comparison between the stirring method and the multipoint method (three points) outdoors.

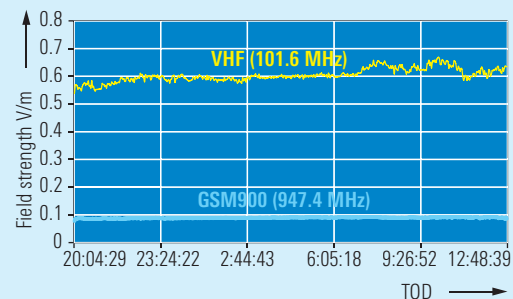

FIG 4 Timing of field strength indoors if transmit power is constant.

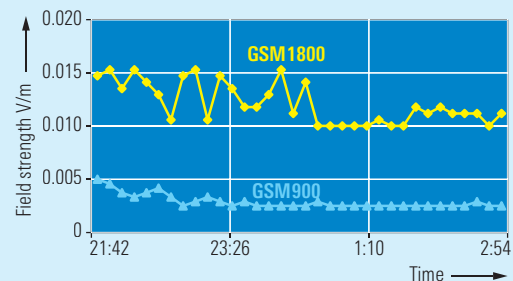
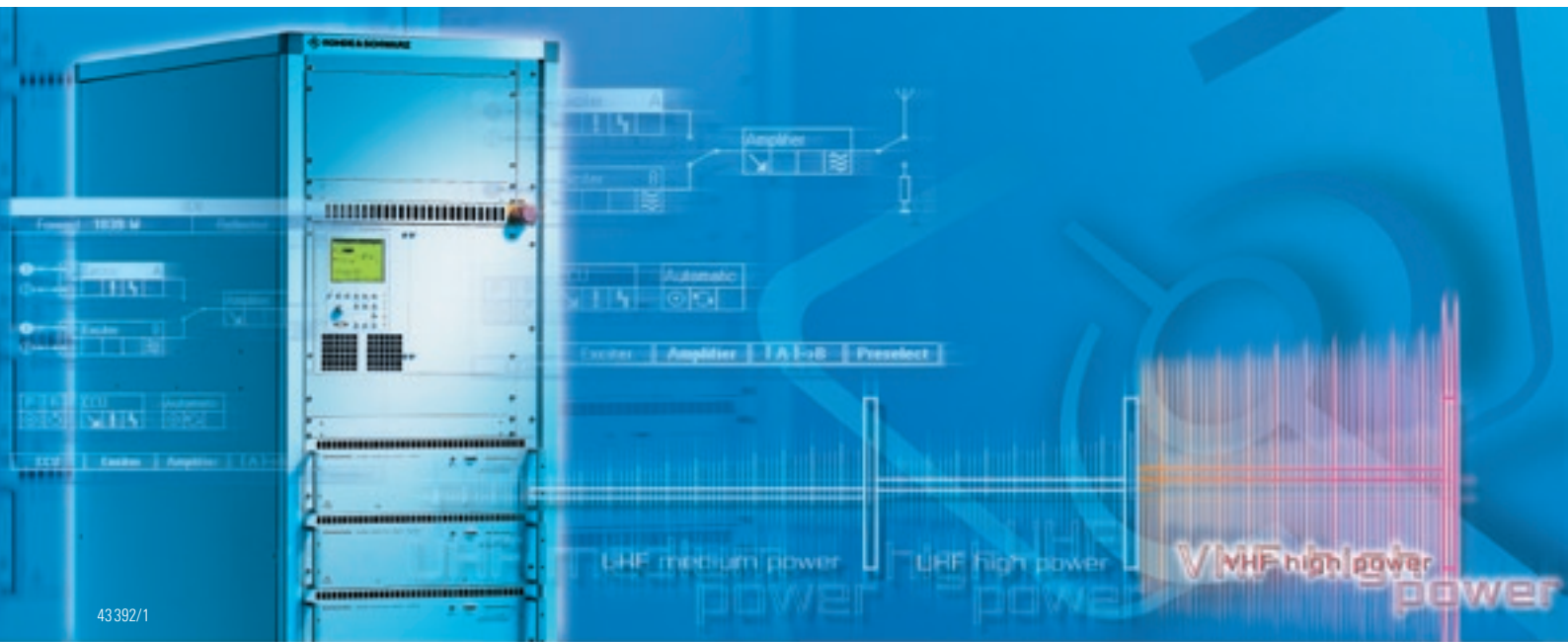

FIG 5 Changed timing of the sum field strength with GSM due to shifting traffic volume.



43392/1

## DAB VHF Transmitter Family R&S® NA 7000

# Liquid-cooled high-power DAB transmitters

The new liquid-cooled DAB VHF Transmitter Family R&S® NA 7000 helps operators to significantly cut costs for installation and in particular for operation.

### Expanding the DAB transmission networks

Digital audio broadcasting (DAB Eureka project 147) has been introduced in numerous countries since it offers more programs with excellent audio quality plus new auxiliary features. The nationwide full-coverage emission of digital sound broadcast programs presents a challenge to broadcasting companies. Trailblazers are Germany, Great Britain, Belgium and Spain, where the capability to receive digital broadcast programs in band III (174 MHz to 240 MHz) has already made enormous progress.

Particularly powerful DAB transmitters with more than 1 kW transmit power are needed in order to set up the main transmitter network. Air-cooled systems cover this range only partially (see box on the right).

### Liquid cooling with flair

Based on positive results with liquid-cooled TV transmitters, Rohde & Schwarz now also offers DAB transmitters with this technology, thus providing operators with the following advantages:

- ◆ Higher power classes
- ◆ Minimum space requirements for transmitters and cooling system
- ◆ High reliability without maintenance
- ◆ Long-term stable operating parameters
- ◆ High efficiency of the entire system
- ◆ Less disturbance due to noise
- ◆ Flexible and straightforward installation of the entire system
- ◆ One cooling system for several transmitters

More information and data sheet at [www.rohde-schwarz.com](http://www.rohde-schwarz.com) (search term: NA 7000)



The liquid-cooling system (FIG) is designed in such a way as to ensure that the cooling medium cannot leak even when amplifier modules are replaced. Redundant components ensure high operational reliability. For example, the two integrated pumps can replace each other in the case of failure. Two fans cool the heat exchanger; in this case, too, full operability is maintained if one of these fans fails or is replaced. This innovative cooling system always keeps the transmitter in the optimum operating temperature range, ensuring longer service life. The heat exchanger can be operated in a very wide temperature range.

## Liquid or air cooling?

### The effectiveness of the entire system is pivotal

When considering the effectiveness of broadcast transmitting systems, the efficiency of the transmitter plays a key role. The higher the efficiency, the more effective and cost- and energy-saving the normal operation. All the same, transmitters radiate considerable excessive heat that must be dissipated.

In the past, air-cooling systems were the standard solution with the focus solely on favourably priced transmitters. However, the expenses incurred by investing in, installing and operating an air-cooling system are not to be ignored either, since filters, wide-diameter air lines, air chambers and separate rooms for fans and elaborate air treatment facilities require considerable space.

A cost analysis of complete transmitter systems, taking into consideration the entire facility, shows that liquid cooling is more economical for transmitters starting at 1 kW in power.

## Uniform transmitter concept presents advantages

The concept of the DAB VHF Transmitter Family R&S® NA 7000 is based on digital VHF TV transmitters and offers transmission power ranging from 0.9 kW to 3.6 kW. Key components such as amplifier, power supplies, housing, combiner and cooling system are identical, ensuring immediate availability and a uniform service concept.

If liquid-cooled DTV and DAB transmitters are operated together at one location, the operator also benefits from the fact that the cooling system can be shared by both transmitter types – thus space requirements can be significantly reduced.

## High redundancy ensures operational reliability

Not only the cooling system with its redundancy and operation monitoring has been designed to be highly fail-safe. The transmitter itself also features facilities that maintain operation if internal components experience interference. All amplifier modules are equipped with their own power supply so that operation errors and failures are limited to one amplifier module. In such a case, the transmitter remains in operation with the transmit power somewhat reduced. Defective components can be replaced during operation.

A redundant exciter is available as an option; in this case, too, separate power supplies are used.

The ETI transmitter signals can be applied in duplicate at the transmitter. If one signal fails, switchover to the second ETI signal is performed seamlessly without interference.

## Liquid cooling: a winning solution

The new DAB VHF Transmitter Family R&S® NA 7000 helps operators to significantly economize on installation and operation, not to mention the costs saved through its minimum space requirements. Customers, in Great Britain for example, have already been won over by the advantages of the liquid-cooling system and its uniformity with other transmitter families from Rohde & Schwarz (see Newsgrams on page 62).

Torsten Jäkel



43-392/6

The liquid-cooling system boasts high operational reliability and minimum space requirements.

# Mobile FM transmitter system for Bayerischer Rundfunk

**Bayerischer Rundfunk (Bavarian Broadcast Corp.) has commissioned Rohde & Schwarz FTK GmbH to supply a mobile FM transmitter system (FIG) to ensure that subscribers receive uninterrupted coverage of its sound broadcast programs during extended transmitter downtimes, e.g. during renovations or when replacing transmitter systems. Such a container eliminates having to take the usual provisional measures in a transmitter building, such as assembling an entire transmitter system with all vital facilities. The transportable VHF transmitter system is equipped with all peripherals required for the automatic operation of five 5 kW FM transmitters plus a standby transmitter according to the (n+1) standby configuration.**

## Five 5 kW FM transmitters and an (n+1) standby transmitter

The container can be shipped by means of a standard container lorry (20 ft or approx. 6 m). It is so robust that it can be transported even on routes without a road surface. It can also be moved via helicopter and crane. The container is equipped with secure electromechanical lifting devices that allow it to be loaded and unloaded by just one person, if necessary.

The VHF transmitter system can be operated onsite via a central control unit and a remote-control system. A parallel interface for commands and messages is supplied as well.

USL-D plug-on switches are available for RF switchover of the transmitters; they are easily accessible for manual opera-

tion. If a switch fails, the RF connections are provided by means of shorting plugs.

The transmitter combining filter can be adapted to all frequency combinations that occur at Bayerischer Rundfunk stations. The dry, air-cooled test load is connected via an RF matrix and dimensioned in such a way that the entire transmitter power of the system can be switched to the test load. It is thus possible to test the system with all switch-over facilities in actual operation.

A common ventilation system equipped with a passive standby is installed for all transmitters.

An ice protection roof shields the transmitter system against falling ice and can even be converted to a sun protection roof in summer.

Reinhard Kasueske

The container accommodates five 5 kW FM transmitters and an (n+1) standby transmitter.



44 034/1

## The donna wears leopard



**Although numerous Italian experts were involved in developing the DVB standard for digital TV, they have so far seen it implemented only in other countries. Digital TV has now finally been given the go-ahead also in Italy. Rohde & Schwarz is involved, thus further expanding its international leading position as a supplier of DVB transmitters.**

is almost impossible without switching off previous analog channels. For years, Italy has been engaged in fierce political discussions on how to handle the transition from analog to digital as well as on the ensuing consequences for the broadcasting landscape, and some of these discussions are still going on. The selected transition model was given the wonderful name "leopard spots" because the digital network is being expanded "spot by spot" wherever a frequency can be made available.

The go-ahead was finally given this summer. The legislation calls for 50% of the population to be supplied by the end of 2003, and even 70% by the end of 2004. For the time being, both RAI and Mediaset have been assigned two multiplexers each, while La7 will operate one multiplexer.

Mediaset has become the trailblazer. Since all channels are also available via satellite, frequencies that have been freed up (also purchased ones) were used for the first digital multiplexer. In the invitation to tender for setting up the digital network of Elettronica Industriale (the network operator of Mediaset) Rohde & Schwarz succeeded in securing a 40% share against tough national and international competition. The company was especially pleased that numerous transmitters of the new R&S® SV 7002 low-power family will be used for this purpose. Moreover, the order also includes stations with models from the R&S® NV 7001 medium-power family that are already well established on the market and the liquid-cooled R&S® NV 7000 high-power family. By the end of the year, the network will be on the air with two multiplexers.

Of course, RAI did not want to miss out. To obtain sufficient frequencies for its digital network, RAI was forced to purchase the necessary frequencies from small private transmitter operators and will therefore need a bit more time to set up the new transmitter network.

The privatized subsidiary RaiWay is handling the setup. The invitation to tender for this project was also hotly contested. Together with its cooperation partner Sirti, Rohde & Schwarz was able to submit a quotation that was both technically and commercially very attractive, securing two thirds of the transmitter network including monitoring receivers. All in all, about 70 transmitters with output power ranging from 25 W to 5 kW will be supplied so that once again all current product families will be used.

This success could not have been achieved without the powerful onsite presence of Rohde & Schwarz Italia, also ensuring long-term technical support for the supplied infrastructure beyond the warranty period.

For Rohde & Schwarz, these projects signify an important breakthrough in Italy where competing against a multitude of national manufacturers is particularly difficult. Following the successfully established large networks in Great Britain (see also page 62), Spain and Scandinavia as well as numerous completed projects in other European and non-European countries, the company has now been able to further expand its leading position in digital TV.

Thomas Loichinger;  
Friedrich Rottensteiner

If you are familiar with Italy, you know how many different TV programs can be received via an antenna even in the tiniest villages. There is the public broadcasting station RAI with three channels, a number of commercial broadcasters such as Mediaset with three channels and then the third-largest chain La7 with two channels, not to mention innumerable regional and local stations.

This leaves only a few frequencies freely available so that structured frequency planning for new digital multiplexers

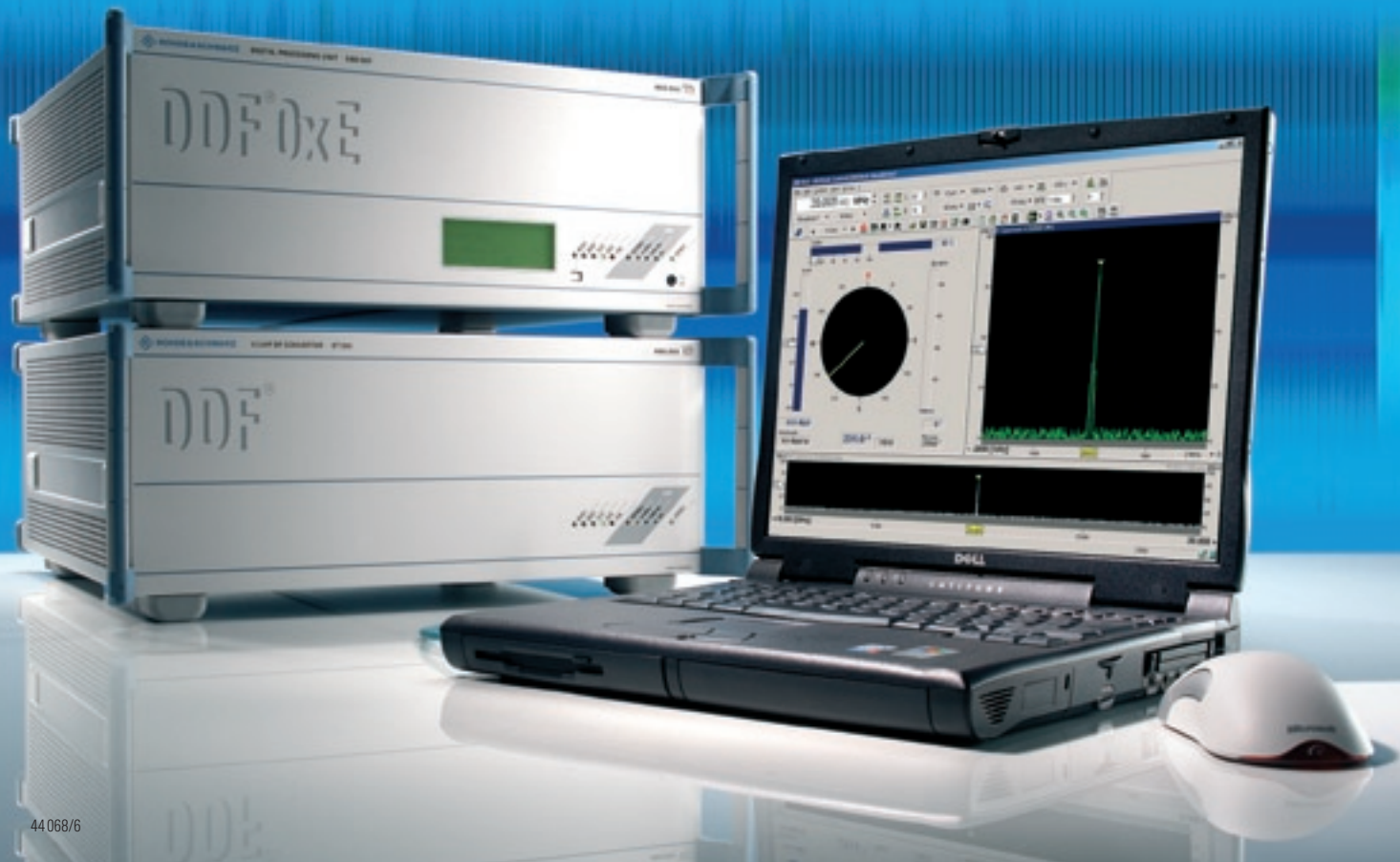

44 068/6

**FIG 1** With only two 19" units, a DF converter and the Digital Processing Unit R&S® EBD061, the entire VHF/UHF range from 20 MHz to 3000 MHz or the HF range from 300 kHz to 30 MHz (optionally 9 kHz to 30 MHz) is covered. Two DF converters and the Digital Processing Unit R&S® EBD061 are required to expand this range from HF through to UHF.

## Digital HF/VHF/UHF Monitoring Direction Finder R&S DDF® 0xE

# Complex radio scenarios monitored at a glance

The new R&S DDF® 0xE is the latest addition to a long tradition of monitoring direction finders from Rohde & Schwarz. Its predecessors were the PA005, PA010 (1980) and PA055 (1985) Doppler direction finders and the R&S DDF® 0xM (1995), the first representative of the digital direction finders.

### Design and function

New broadband transmission methods call for new tools in radiomonitoring with the direction finder playing a key role. Conventional monitoring direction finders analyze the signal in the selected frequency channel; scanning mode and spectrum display help to select the channel of interest. With broadband and short-term signals, however, only the quasi-simultaneous direction finding of a multitude of frequency channels enables quick and easy evaluation of difficult radio scenarios. This applies in par-

ticular to short-term signals of unknown frequency and to spectrally overlapping signals.

Depending on the selected resolution bandwidth, direction finders of the R&S DDF® 0xE family (FIG 1) are able to take bearings of up to 10000 frequency channels simultaneously in the realtime bandwidth of 1 MHz in the HF range and of 2 MHz in the VHF/UHF range; even complex scenarios can thus be monitored and evaluated. FIG 4 shows the example of the direction finding results of a VHF signal scenario: Only broad-

band direction finding – in this case covering 2 MHz with 5 kHz resolution – provides information about the pulsed signal of approx. 600 kHz in width that arrives from an angle of 260°.

Basically, there are three versions of the R&S DDF®0xE family:

- ◆ **R&S DDF®01E** HF range  
0.3 MHz to 30 MHz
- ◆ **R&S DDF®05E** VHF/UHF range  
20 MHz to 3000 MHz
- ◆ **R&S DDF®06E** HF to UHF range  
0.3 MHz to 3000 MHz

Each direction finder consists of a **DF Converter R&S®EH110** (0.3 MHz to 30 MHz) and/or the **R&S®ET550** (20 MHz to 3000 MHz) as well as the **Digital Processing Unit R&S®EBD061** (FIG 2). The main differences between the R&S DDF®0xE und and its predecessor, the R&S DDF®0xM, are listed below:

- ◆ Increased FFT realtime bandwidth (VHF/UHF: 2 MHz, HF: 1 MHz), resulting in enhanced measurement functions and higher search speed

- ◆ The entire VHF/UHF frequency range from 20 MHz to 3000 MHz is covered by a single DF converter
- ◆ Connection to the control processor is via an Ethernet interface (100 Mbit/s), enabling universal system solutions and even allowing the use of laptop computers as controllers
- ◆ Enhanced receiver characteristics: The excellent dynamic range characteristics of the DF Converters R&S®EH110 and R&S®ET550 are unrivalled
- ◆ Antenna controlled by the DF processor; an optionally integrated compass in the DF antenna can thus be read quasi-continuously
- ◆ Expanded and improved user interface

The complete DF antenna portfolio of the R&S®ADDxxx series (which was already available for the Direction Finders R&S DDF®0xM) can be used with the new direction finders. The R&S®ADD150 DF antenna (20 MHz to 1300 MHz) was revised and now exhibits sensitivity increased by up to 10 dB in the 20 MHz to 100 MHz range.

## Operating modes

Like the preceding generations, the R&S DDF®0xE also offers three DF modes:

**Fixed Frequency mode (FFM)** The direction finder is operated at a discrete frequency and displays the results bearing, level, DF quality as well as elevation in digital and analog form in the HF range when operated as a correlative interferometer (FIG 3). It also presents an FFT realtime spectrum with selectable span that is centered to the selected frequency. The analog bearing is displayed either as a polar display or as a histogram with waterfall. In this mode, the received signal can be demodulated, and the most adequate bandwidth can be selected independently of the set DF bandwidth.

The **DF mode FFM** offers several capabilities for squelch-controlled averaging that is always based on the type of signal to be detected:

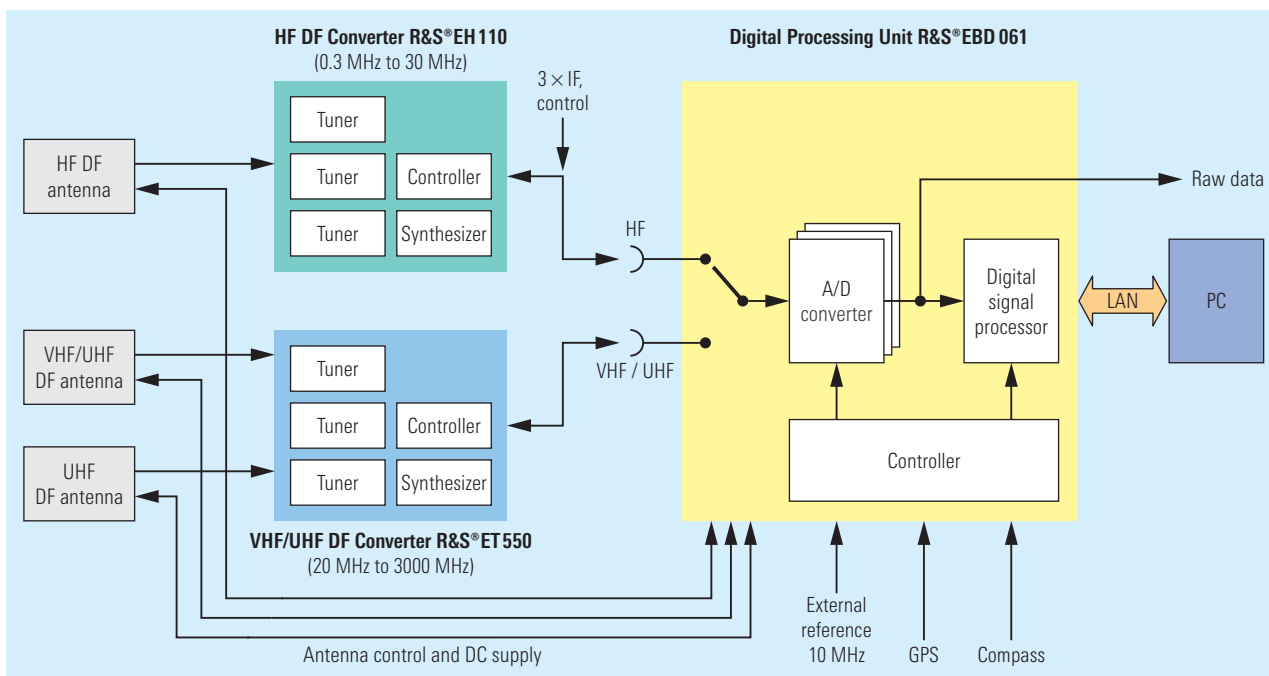

FIG 2 Block diagram of the R&S DDF®0xE direction finders.

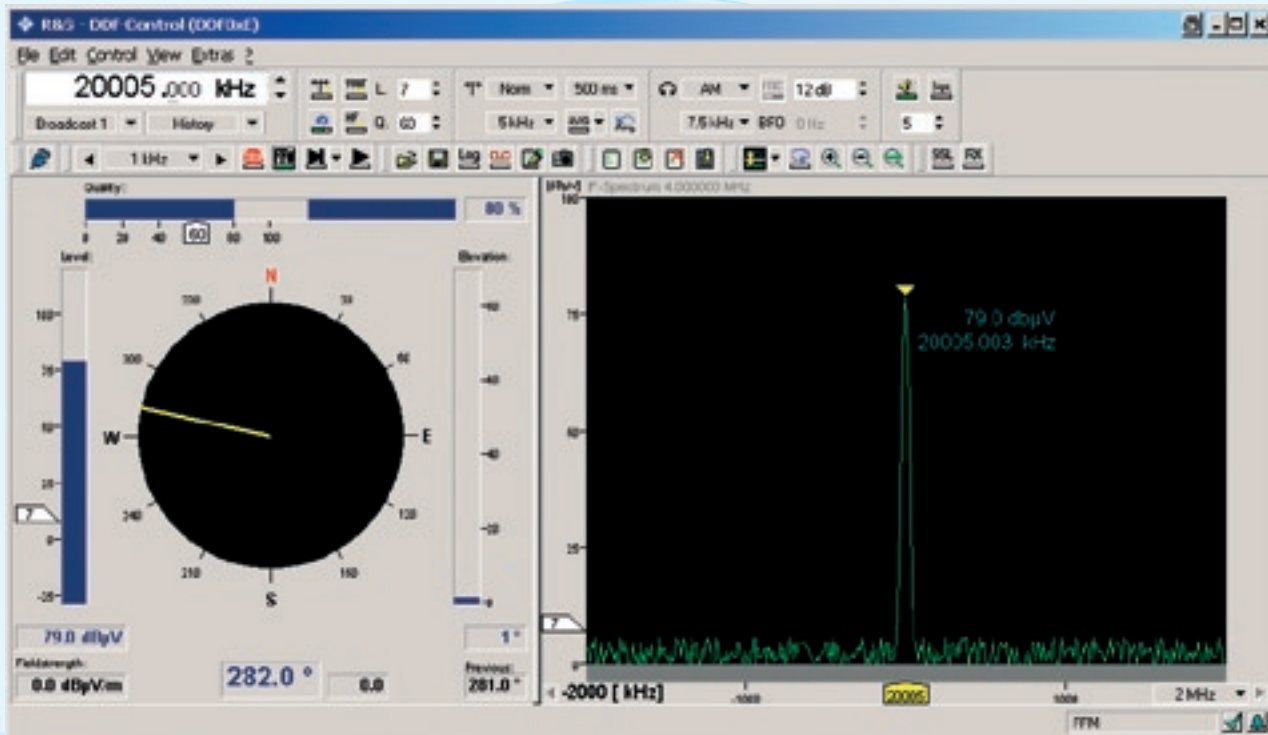
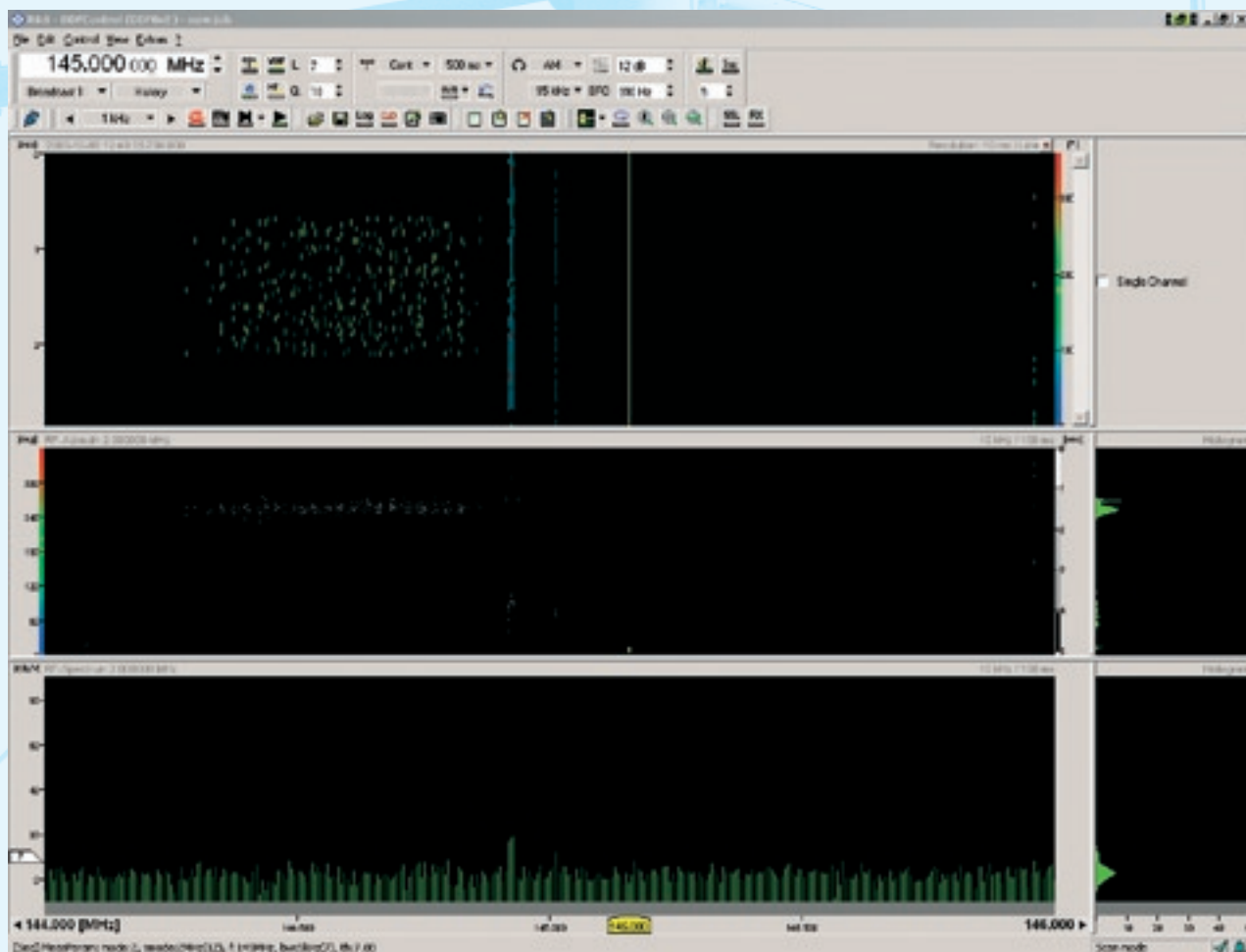

FIG 3 Result display in the Fixed Frequency mode.

FIG 4 Display of the DF results of a VHF signal scenario at 2 MHz realtime bandwidth with 5 kHz resolution.





- ▶ ◆ **NORMal** This type of averaging is used for normal communication between different stations within a network; the content of the averaging memory is deleted at the beginning of each new emission. The bearing display thus jumps from one angle of incidence to the next without delay.
- ◆ **GATE** This type of averaging is used for the pulse sequence of a transmitter (e.g. Morse), or if a transmitter is overmodulated so that modulation gaps occur. In this case, the averaging memory is not deleted, but averaging follows the previous result at each new pulse. Thus, pulse sequences appear as continuous-wave signals, and system sensitivity increases.
- ◆ **CONTinuous** With this type of averaging, the squelch threshold is disabled. Although a bearing is now taken of any HF energy, especially noise, it is possible to obtain bearings even of very weak signals by defining a minimum DF quality value.

**SCAN mode** For this operating mode, a frequency range with start and stop frequency as well as step width (FFT resolution) are first defined. As an alternative, a list with frequencies can also be created (up to 1000 entries). In addition, the evaluation threshold (squelch) and, if required, a minimum DF quality value must be defined. Moreover, up to two azimuth sectors within which bearings are of interest can be specified, as well as an elevation range in the HF range (when operated as a correlative interferometer). It is also possible to define sub-ranges or lists with frequencies offering results that are not of interest and which should therefore be suppressed, also with a view to data reduction.

There are various result displays (FIG 4): amplitude versus frequency (spectral display), azimuth versus frequency, time versus frequency (waterfall), elevation versus frequency. As an additional

means of identification, the results can be assigned colours, with colour coding linked either to level, azimuth or elevation. For a more in-depth analysis of specific subranges, quick zooming to the display is possible, increasing the probability of intercept. By double-clicking a frequency or pressing a function key, fast switchover from SCAN mode operation to FFM is possible.

**SEARCH mode** As with the SCAN mode, frequency ranges or frequency lists are also defined. In the SEARCH mode, however, the direction finder will interrupt the search each time it encounters a signal that exceeds the fixed threshold, and it will dwell on this signal for a previously defined period of time to allow the user to "listen in" to the signal. Display in this operating mode is identical to that in FFM.

To operate the direction finder and display the results, an external controller with the Windows® 2000/XP operating system is required that is connected via a LAN interface (100 Mbit/s). This offers the advantage that also laptops can be used as controllers. The operating software is part of the equipment supplied with the direction finder. But the direction finder is not only suitable for direct local operation – it can also be operated over large distances and integrated into complex interception and radiolocation networks such as the R&S® ARGUS or R&S® RAMON.

## Options

There are, of course, a multitude of options available for the R&S DDF® 0xE direction finders, including:

- ◆ **R&S DDF® E-REM** For DF remote control over large distances.
- ◆ **R&S DDF® -GSM** Determines the associated bearings for the individual timeslots of a GSM mobile phone channel.

- ◆ **R&S DDF® -SSL** Performs single-station location (SSL) in the short-wave range (correlative interferometer).
- ◆ **R&S® RA-MSH** For controlling handoff receivers via the direction finder.
- ◆ **Preclassifier R&S DDF® CL** For effective data reduction. By using the preclassifier, it is possible for example to automatically detect frequency-hopping transmitters in the SCAN mode and determine their angle of incidence.

Franz Demmel; Ulrich Unselt

More information and data sheet at  
[www.rohde-schwarz.com](http://www.rohde-schwarz.com)  
 (search term: DDF0xE)



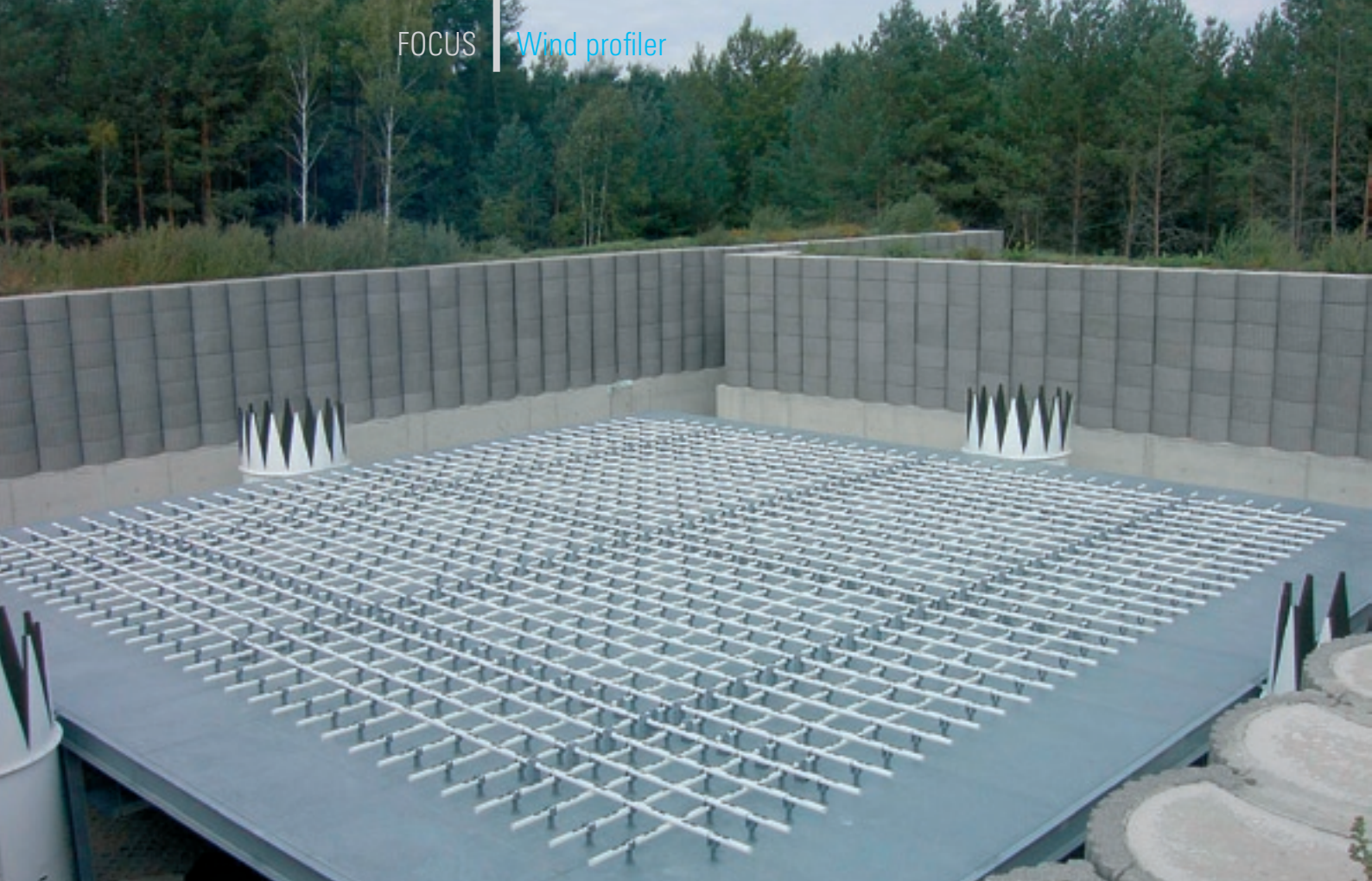

Photo: author

Wind profiler antenna field in Ziegdorf (Brandenburg) with a total of 180 elements and a gain of 36 dB. An effective isotropically radiated power (EIRP) of 48 MW is achieved.

## Wind profiler for the German Meteorological Service

**Rohde & Schwarz FTK GmbH delivered a shelter station for a wind profiler that went into continuous operation at the German Meteorological Service in September 2003. The pulse transmitter is a modified DVB-T transmitter from Rohde & Schwarz. The radar reception equipment is provided by the Finnish company VAISALA.**

### What is a wind profiler?

#### Measurement of wind vectors

A wind profiler is a complex transmitting/receiving radar station used to measure wind speed in the atmosphere at altitudes between 500 m and 16 km. A pulsed radar signal is radiated into the troposphere in the form of five main radiation lobes, with four of them arranged at a 15-degree angle around the center vertical lobe. The signals are reflected by the atmosphere with different Doppler shifts as a result of turbulent fluctuations (called refractive index fluctuations). A radar receiver registers the reflections and evaluates their propa-

gation time with signal processing software to determine different altitude layers. The result is a set of three-dimensional wind vectors covering the altitude.

#### Measurement of virtual temperature

The radar in the wind profiler can also be used relatively easily to measure virtual temperature by expanding the system to form a radio acoustic sounding system (RASS) by placing four acoustic sources (large loudspeakers) around the wind profiler antenna. The vertical sound radiation generates an acoustic pattern of atmospheric density fluctuations that is sampled with the electromagnetic waves of the wind profiler. The

acoustic waves propagate in the atmosphere at the velocity of sound, which varies depending on atmospheric density. This temperature-dependent velocity of sound can be determined up to an altitude of 4 km with software, and the virtual temperature can then be calculated.

## Wind profilers as early warning systems

First attempts to determine wind speeds using multifrequency measurements took place in the 1960s (see box on page 60), ultimately leading to the modern wind profiler. The USA now has more than 100 such systems. They provide early warning of inclement weather, thus protecting the population.

Wind profilers also considerably lower costs for meteorological services by greatly reducing the use of weather balloons. Further advantages include:

- ◆ High time resolution of measurements (typically 30 minutes)
- ◆ Up-to-date reports (nowcasting)
- ◆ True Eulerian character of the measurement (overhead profile)
- ◆ Instant profiles since measurement occurs at all altitudes simultaneously
- ◆ Automatic operation

## Transmitters from Rohde & Schwarz

Approximately five years ago, Rohde & Schwarz FTK GmbH – the specialist for sound broadcasting and data-casting within the Rohde & Schwarz group of companies – took part in the development of a prototype for a wind profiler. At that time, a modified television transmitter equipped with tetrodes was used. Today, this prototype is in operation at the Lindenberg observatory, approx. 80 km east of Berlin.



Photo: DWD

The prototype of a wind profiler near the German Meteorological Service in Lindenberg (Germany) which Rohde & Schwarz helped develop.

All transmit/receive equipment for the wind profiler in Ziegendorf is accommodated in two racks, which fit into a shelter. The pulse transmitter is a modified DVB-T transmitter from Rohde & Schwarz.



Photo: author

► The introduction of LDMOS technology and the production of the latest generation of the extremely reliable, water-cooled DVB-T transmitters of the R&S® Nx7000 family from Rohde & Schwarz also made it possible to outfit wind profilers with solid-state transmitters. This unusual application required finding solutions to a number of tricky technical problems such as the following:

- ◆ The transmit amplifiers had to be made switchable. Unusually short switching times are required for this power class. The blocking of RF stages now takes only approx. 250 ns (1 µs required).
- ◆ The requirements for residual noise power density in the pulse pauses are extremely sophisticated. A value of approx. -172 dBm (1 Hz) is now achieved at 25 °C (-160 dBm (1 Hz) required).
- ◆ A highly sensitive receiver is activated in the pulse pauses. The transmitter and receiver are interconnected via a circulator with (finite) decoupling and operate in a shared antenna field. During reception, the transmitter and its noise must not drown out weak reception signals. With respect to noise, it must function like an ohmic resistor.

The expertise from all participating companies is paying off: The evaluations made to date indicate that the system is very reliable and definitely yields more exact data than the prototype.

Michael Morgenstern

**The most important specifications for the wind profiler**

Transmit power	16 kW to 18 kW
Pulse times	1.7 µs to 60 µs
Pulse pauses	30 µs to 600 µs
Duty cycle	<15%
Frequency	482.0078 MHz
Noise power density in the pulse pauses	<-170 dBm (1 Hz)
LNA noise figure	0.5 dB
LNA gain	30 dB

**Wind profiler history**

- ◆ **1966** First verified clear-air echoes in multifrequency measurements on Wallops Island (3.2 cm, 10.7 cm and 71.5 cm radar)
- ◆ **1969** First wind measurements under clear-air conditions, 2.8 GHz, Wallops Island
- ◆ **1974** 50 MHz ionospheric radar at Jicamarca (Peru)
- ◆ First specially constructed wind profiler
  - **1975** 40 MHz Sunset radar at Boulder, Colorado (USA)
  - **1976** 53.5 MHz SOUSY radar near Katlenburg Lindau (in Lower Saxony, Germany)
- ◆ First wind profiler measurement networks
  - **1991** Wind Profiler Demonstration Network, 32 systems (404 MHz)
  - **1984** Colorado Wind Profiler Network (5 systems)

**Related Internet links:**

- ◆ [www.dwd.de](http://www.dwd.de)
- ◆ [www.profiler.noaa.gov](http://www.profiler.noaa.gov)
- ◆ [www.fsl.noaa.gov](http://www.fsl.noaa.gov)
- ◆ [www.etl.noaa.gov/data](http://www.etl.noaa.gov/data)
- ◆ [www.metoffice.com/research/interproj/cwinde/profiler](http://www.metoffice.com/research/interproj/cwinde/profiler)
- ◆ [www.vaisala.com](http://www.vaisala.com)

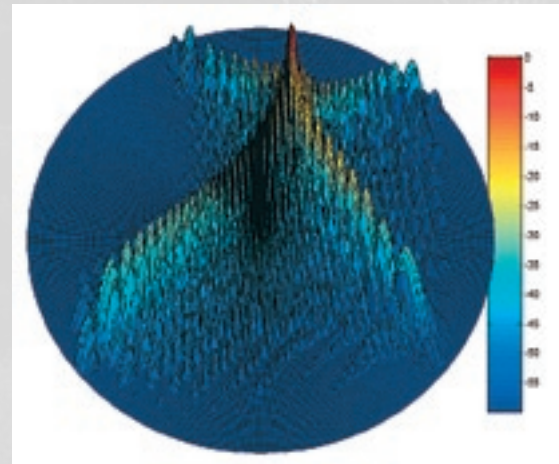

Radiation pattern of the antenna field with a relative antenna gain in dB. The radiation lobes in four directions are clearly shown. The main direction of radiation is shifted by approx. 15° every 40 seconds.

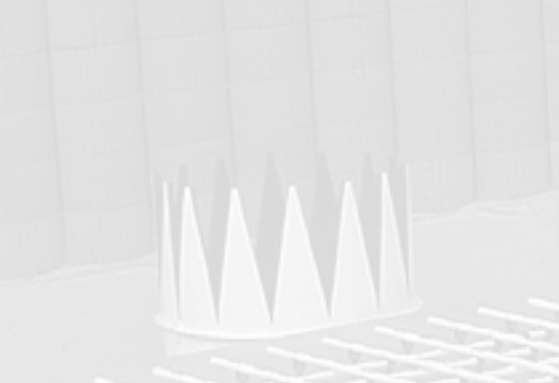

Photo: author

Powerful loudspeaker towers expand the radar system to form a RASS for measuring virtual temperature. They generate a sound pressure of 135 dBa at a height of 2 m.

The typical radiated radar spectrum (max. hold measurement, pulse length 1700 ns, 482 MHz).

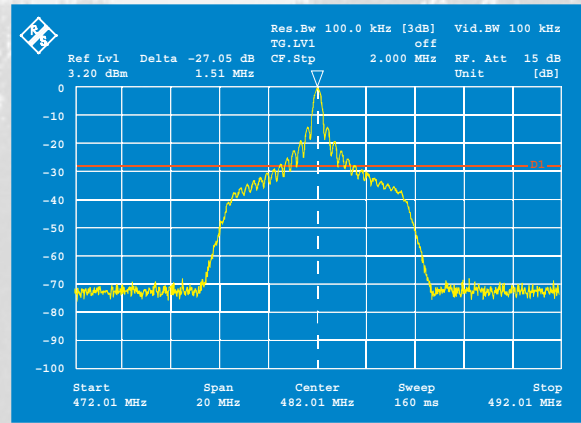

Photo: Jens Mogensen, VAISALA

The wind profiler in Ziegendorf: The antenna platform with 180 antenna elements (90 in North / South direction, 90 in East / West direction) and four lateral loudspeakers can be seen in the center. The shelter is at the front. The earthen wall prevents interactions with TV transmitters in adjacent channels and blocks the radiation of side lobes with flat radiation angles. Moreover, Doppler reflections need to be shielded from wind-driven power stations that are in the vicinity.



Photo: author

The shelter holds the transmitter, receiver and radar equipment. It is custom-built by NAUTECH, which is a company specializing in customized shelters. The exterior and interior walls are specially designed to be fireproof.



◀ **New Head of the Test and Measurement Division**

**Roland Steffen (51) is the new Head of the Test and Measurement Division at Rohde & Schwarz and thus in charge of development, production and marketing of the company's T&M instruments and systems. Along with his new position, he has been appointed to the company's Corporate Management. His predecessor, Michael Vohrer, joined the Executive Board on 1 July 2003 (see No. 179).**

**New Managing Director at Rohde & Schwarz Denmark**

Niels Frandsen is the new Managing Director at Rohde & Schwarz Denmark as well as General Manager of the Swedish subsidiary Rohde & Schwarz Sverige AB. He joined Rohde & Schwarz Denmark in 1990 as a sales engineer. He was appointed Sales Manager Test & Measurement in 1996; in 2001 he took over as Sales Manager Test & Measurement at the Swedish sales organization of Rohde & Schwarz. In July 2003, he became General Manager at Rohde & Schwarz Denmark.



Mr Steffen has been with the company for 25 years. Before being appointed Head of Division, he was Director of the Mobile Radio T&M Products Subdivision, which has the largest market share at Rohde & Schwarz and generates the highest turnover. He took over this post in 1996. Prior to that, he was Head of R&D for protocol testers.

Mr Steffen sees future T&M opportunities primarily in the area of mobile radio. "The entire field of wireless communications with mobile phones, base stations and wireless PC interfaces is a growth market and will remain so, even if to a lesser extent than during the boom two years ago. We have a good share of the market here and are ideally positioned," says Mr Steffen. UMTS also holds new opportunities for Rohde & Schwarz, according to Mr Steffen: "UMTS will be here – sooner or later. Our test and measurement equipment is already making a major contribution in setting up networks and in developing and producing reliable UMTS mobile phones and base stations. In a few years these measuring instruments will make up a significant percentage of our turnover."



**Fundamentals of spectrum analysis now in Spanish**

This comprehensive introduction to spectrum analysis (for a review, see News from Rohde & Schwarz (2001) No. 171, page 19) covers both the theory and its application in typical T&M tasks. It has now been published also in Spanish by the Rohde & Schwarz inhouse publisher and is available from Rohde & Schwarz sales offices.

**Pilot project in Poland launched: TETRA radio network to increase internal security**

**The Polish government has commissioned a pilot project to set up a modern radio system with a view to improving internal security and cooperation among rescue teams. R&S BICK Mobilfunk GmbH, a subsidiary of Rohde & Schwarz, supplied and installed the TETRA ACCESSNET®-T radio system in the new control center in Człuchow.**

At the opening, the Polish Minister of the Interior, Krzysztof Janik, who made a special trip for this event, was shown the functions and benefits of direct radiocommunications between police, firefighters, rescue services and control center. The purpose of the project launched by Mr Janik was to promote closer cooperation among the operational forces, thus giving citizens an increased sense of safety. A new control center was specifically set up for this project, and cameras and emergency telephones were installed. Potential troublespots such as busy crossings or public places are monitored by these cameras. The emergency telephones enable direct and immediate contact with the control center

where the rescue teams and emergency services are instantly coordinated via TETRA.

**Rohde & Schwarz supplies DAB transmitters for the British Broadcasting Corp. (BBC) network**

**The British network operator Crown Castle UK Limited has commissioned**



## Rohde & Schwarz to supply 47 DAB transmitters.

The transmitters operate in power classes ranging from 250 W to 3.8 kW and are used to expand the digital broadcast network of the BBC. The order includes air-cooled transmitters from the R&S® NA 6000 family and liquid-cooled DAB transmitters from the new R&S® NA 7000 series (page 50) which are considered the most compact transmitters in the high-power class. The R&S® NA 7000 requires only a minimum of space, is quick and easy to set up and makes considerably less noise than comparable air-cooled high-power systems. Other reasons behind Crown Castle's decision in favour of Rohde & Schwarz were the company's long-standing expertise in digital broadcasting and TV as well as its reliable product support. The contract emphasizes the leading role of Rohde & Schwarz in setting up the digital broadcasting network in Great Britain.

## International 3G standardization body meets at Rohde & Schwarz

### Rohde & Schwarz hosted the 20th 3GPP T1 meeting in Munich from 28 July through 01 August 2003.

With approximately 60 participants, this international meeting of the standardization bodies for user equipment for third-generation mobile radio (3G) was exceptionally well attended. Numerous mobile radio manufacturers from the Far East, North America and Europe – among them many customers of Rohde & Schwarz – were present with their own experts. Several working groups held meetings and discussions in parallel, thus handling an enormous number of RF and signaling questions. The experts were especially satisfied with the tremendous progress made in 3GPP TTCN test case verification, which is due in no small part to Rohde & Schwarz.



### Rohde & Schwarz hosts the experts of the 20th 3GPP T1 meeting from 28 July through 01 August 2003.



Dr Hartmut Ilse (right) is in charge of the new support center for security products.



### Support center for security products has opened

**A service and support center exclusively for security products has now opened at the Berlin headquarters of Rohde & Schwarz SIT GmbH.**

Its aim is to provide direct and yet more efficient support to customers using encryption solutions. Application support for the TopSec devices and the SITLink encryption unit for leased lines will be provided from here. Dr Hartmut Ilse, an experienced specialist in cryptology, heads the support center.

#### Security support center:

Phone: +49 3065884-111

E-mail: [support@sit.rohde-schwarz.com](mailto:support@sit.rohde-schwarz.com)

### Rohde & Schwarz opens service center in the USA

**To offer direct access to the manufacturer and thus better support to customers in the USA requiring service, Rohde & Schwarz has now taken over the service activities of its sales partner**

**Tektronix in the USA. Especially with the servicing of high-end capital goods such as Rohde & Schwarz products, local support ensures even faster handling while maintaining high quality and a good price/performance ratio.**

"US customers will receive the same high standard of service and expertise as from Tektronix, but they now additionally benefit from direct access to the manufacturer," says Barry Fleming, the new US Service Manager. Together with all Tektronix engineers and support experts who were previously responsible for Rohde & Schwarz, he switched from the Tektronix service organization to the new Rohde & Schwarz service center in Columbia, Maryland, on the East Coast. The center offers a service platform with various automatic calibration systems (ACS) and is able to carry out repairs, complete calibrations or customized measurements on specific test points. In the future, service will be further enhanced by calibration capabilities for high-frequency and microwave technology.

Visit us on Internet at [www.rohde-schwarz.com](http://www.rohde-schwarz.com)



**ROHDE & SCHWARZ**

Rohde & Schwarz GmbH & Co. KG · Mühl Dorfstrasse 15 · 81671 München, Germany · P.O.B. 80 14 69 · 81614 München  
Support Center: Tel. (+49) 18 05 12 42 42 · E-Mail: [customersupport@rohde-schwarz.com](mailto:customersupport@rohde-schwarz.com) · Fax (+49 89) 41 29-137 77